

PRODUCT NUMBER
91615-YXXZWLF

- RoHS COMPATIBLE, SEE NOTE 7
- OPTIONAL LETTER SEE SHEET 2
N: PRODUCT WITH TYPE MARKING ON CONNECTOR
- OPTIONAL LETTER
A: PRODUCT WITH PICK UP CAP PACKED IN TAPE & REEL SEE TA856.
B: PRODUCT WITH PICK UP CAP PACKED IN TUBE.
AV: CUSTOMER DEDICATED PRODUCT WITH PICK UP CAP PACKED IN TAPE & REEL SEE TA856.
- NUMBER OF POSITIONS PER ROW: 03 UP TO 30.
MORE THAN 30 POSITIONS ON SPECIAL REQUEST.
- PLATING CODE
3= 0.76µm GOLD ON CONTACT AREA.
2µm MIN MATTE TIN ON TAIL.
4= 2µm MIN MATTE TIN FULL PLATED
1.27µm Ni MINUNDERPLATING

NOTES:

- 1 - HOUSING MAT'L: THERMOPLASTIC GLASS FILLED FLAME RETARDANT PER UL 94 V-0 COLOR: GREY.
- 2 - TERMINAL MATERIAL: PHOSPHOR BRONZE.
- 3 - PACKAGING:
3 UP TO 4 POSITIONS PRODUCT PACKED IN PLASTIC BOX.
5 UP TO 30 POSITIONS PRODUCT PACKED IN TUBE.
WHOLE 91615-303B PRODUCT PACKED IN TUBE.
- 4 - TO DETERMINE DIMENSIONS:
N = NUMBER OF POSITIONS PER ROW
EXAMPLE: 8 POS: $((N+2) \times 2.54) - 0.08 = 25.32$ mm.
- 5 - RECOMMENDED IR PROFILE PER TA842.
- 6 - $\phi 2.65$ MINI FOR PICK & PLACE ASSEMBLY(=0 INSERTION FORCE).
- 7 - RoHS COMPATIBLE PRODUCT SPECIFICATIONS

a - PLATING:

- "LF" MEANS THE PRODUCT IS LEAD-FREE,
2µm MINIMUM MATTE TIN OVER 1.27µm
MINIMUM NICKEL UNDERPLATE.

b - MANUFACTURING PROCESS COMPATIBILITY

- THE HOUSING WILL WITHSTAND EXPOSURE TO 260°C PEAK TEMPERATURE FOR 30 SECONDS MAX IN A CONVECTION, INFRA-RED OR VAPOR PHASE OR REFLOW OVEN.

c - LABELING:

- MEETS PACKAGING SPECS AS PER GS-14-920

d - LEGAL STATEMENT: SEE GS-47-0004

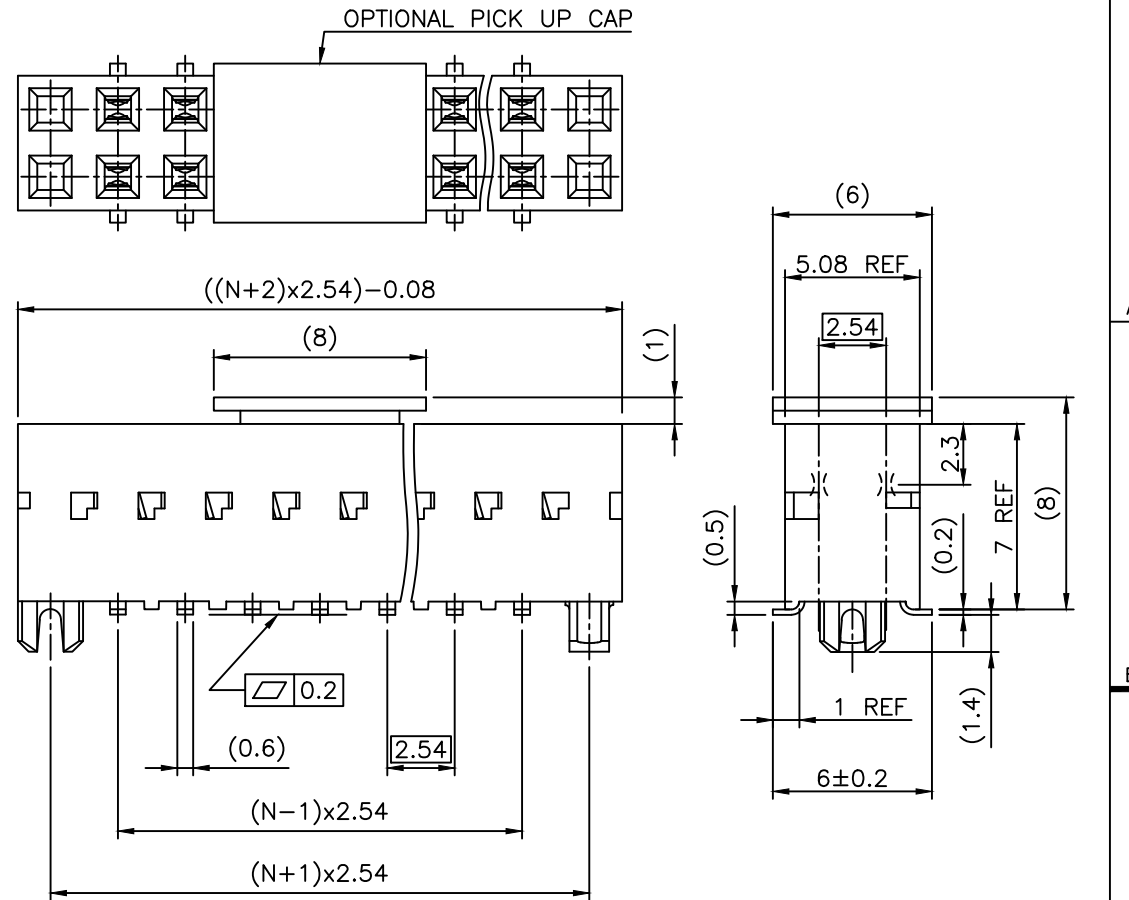

mat'l. code		surface		tolerance		projection		product family	
SEE NOTES		ISO 1302		ISO 406 ISO 1101		mm		DUBOX	
ltr	ecn no	dr	date	tolerances unless otherwise specified		mm		title	
AB	F04-0347	DLE	04.11.10	±0.3		mm		BtB RECEPT. VERT DR SMT	
AC	F06-0137	DLE	06.02.27	angles	linear	scale 5:1			
AD	F06-0204	DLE	06.06.23	±2'					
AE	F07-0165	DLE	07.03.30	dr	P NIZZI	95.11.17		dwg no sheet 1 of 3 size	
AF	B-19123	LMU	14.10.21	enr	P.NZ	01.07.23		91615 A3	
AG	F-34809	DDE	19.09.10	chr	P.NZ	01.07.23		type CUSTOMER Drawing	
				appd	JF.N	01.07.23			
sheet	revision	AG	D	B					
index	sheet	1	2	3					

PRODUCT NUMBER
91615-YXXZNLF

RoHS COMPATIBLE, SEE NOTE 7

APPLICATION SPECIFIC

PRINTING METHOD FOR 91615-Y07 UP TO -Y50
MARKING: PART NUMBER AND DATE CODE

PRINTING METHOD FOR 91615-Y03 UP TO -Y07

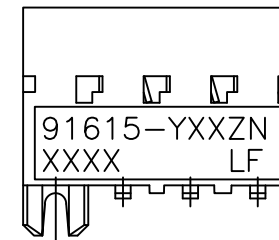
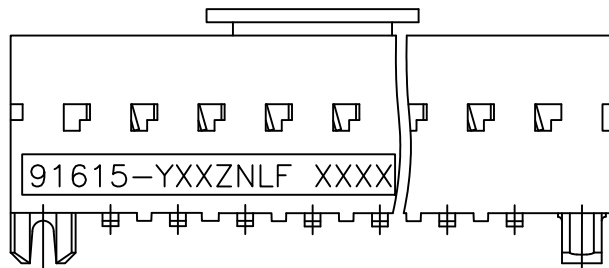

91615-YXXZNLF XXXX

- YEAR CODE
- WEEK CODE
- FOR OTHER OPTION LETTERS SEE SHEET 1
- NUMBER OF POS.
- PLATING CODE



mat'l. code				surface		tolerance		projection		product family	
				ISO 1302		ISO 406 ISO 1101		mm		DUBOX	
ltr ecn no dr date				tolerances unless otherwise specified				title			
A F10379 DLE 01.07.23				angles		linear		mm		BtB RECEPT. VERT DR SMT	
B F04-0347 DLE 04.11.10				±2'				scale N/A			
C F06-0137 DLE 06.02.27										dwg no sheet 2 of - size	
D F06-0204 DLE 06.06.23				dr		D.LE		01.07.23		91615 A3	
E B-19123 LMU 14.10.21				enr		P.NZ		01.07.23		type CUSTOMER Drawing	
				chr		P.NZ		01.07.23			
				appd		JF.N		01.07.23			
sheet index		revision sheet									

Copyright FCJ

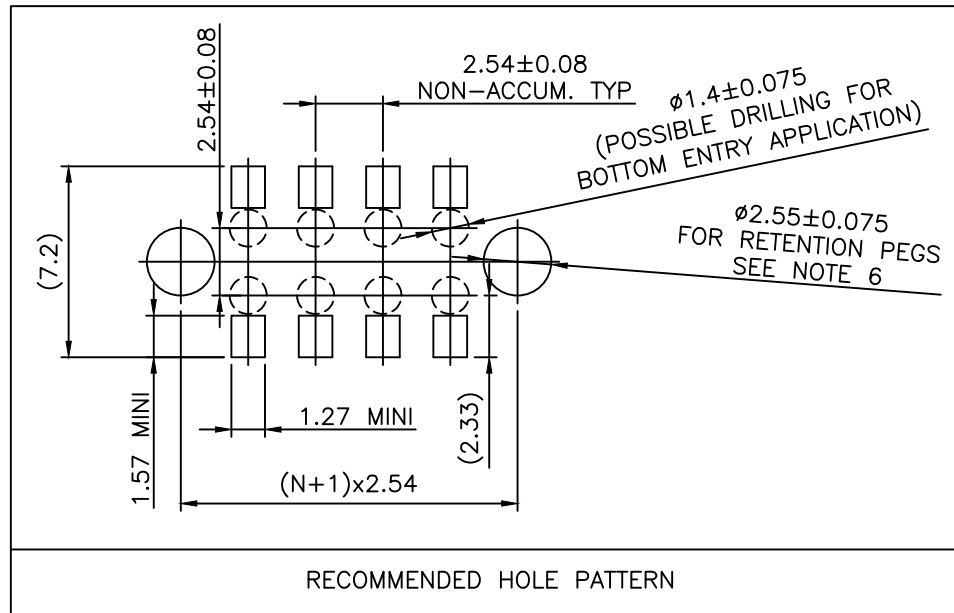

FCJconnect.com



Copyright FCJ

mat'l. code		surface		tolerance		projection		product family	
		ISO 1302		ISO 406 ISO 1101		mm		DUBOX	
ltr	ecn no	dr	date	tolerances unless otherwise specified		mm		title	
A	F04-0347	DLE	04.11.10	angles	linear	mm		BtB RECEPT. VERT DR SMT	
B	F06-0204	DLE	06.06.23	±2'		scale N/A		dwg no	
						FCJ		sheet 3 of - size	
				dr	D.LE	04.11.10		91615 A3	
				enr	P.NZ	04.11.10		type	
				chr	P.NZ	04.11.10		CUSTOMER Drawing	
				appd	P NZ	04.11.10			
sheet index	revision sheet								

Mouser Electronics

Authorized Distributor

Click to View Pricing, Inventory, Delivery & Lifecycle Information:

[Amphenol:](#)

[91615-329LF](#)