

Mounting flange - VC-AF - 1852862

Please be informed that the data shown in this PDF Document is generated from our Online Catalog. Please find the complete data in the user's documentation. Our General Terms of Use for Downloads are valid (<http://phoenixcontact.com/download>)



Panel mounting flange for screw locking, for mounting contact insert modules, for a panel thickness of 1 - 5 mm

The illustration shows the mounting flange with panel mounting frame VC-AR1/2M

Product Features

- Compact design
- Universal connection
- Proven COMBICON technology
- Can be keyed to prevent incorrect connection



Key Commercial Data

Packing unit	1 pc
GTIN	 4 017918 127183
Weight per Piece (excluding packing)	5.58 g
Custom tariff number	85369010
Country of origin	Poland

Technical data

General

Note	2 for every connector
------	-----------------------

Ambient conditions

Ambient temperature (operation)	-40 °C ... 125 °C
Ambient temperature (assembly)	-40 °C ... 70 °C

Material data

Mounting flange - VC-AF - 1852862

Technical data

Material data

Flammability rating according to UL 94	V0
--	----

Standards and Regulations

Flammability rating according to UL 94	V0
--	----

Classifications

eCl@ss

eCl@ss 4.0	27140816
eCl@ss 4.1	27140816
eCl@ss 5.0	27371205
eCl@ss 5.1	27371205
eCl@ss 6.0	27371205
eCl@ss 7.0	27371205
eCl@ss 8.0	27440210
eCl@ss 9.0	27440210

ETIM

ETIM 2.0	EC000437
ETIM 3.0	EC000437
ETIM 4.0	EC000437
ETIM 5.0	EC002310

UNSPSC

UNSPSC 6.01	31261501
UNSPSC 7.0901	31261501
UNSPSC 11	31261501
UNSPSC 12.01	31261501
UNSPSC 13.2	31261501

Approvals

Approvals

Approvals

EAC / EAC / EAC

Mounting flange - VC-AF - 1852862

Approvals

Ex Approvals

Approvals submitted

Approval details

EAC

EAC

EAC

Drawings

Mounting flange - VC-AF - 1852862

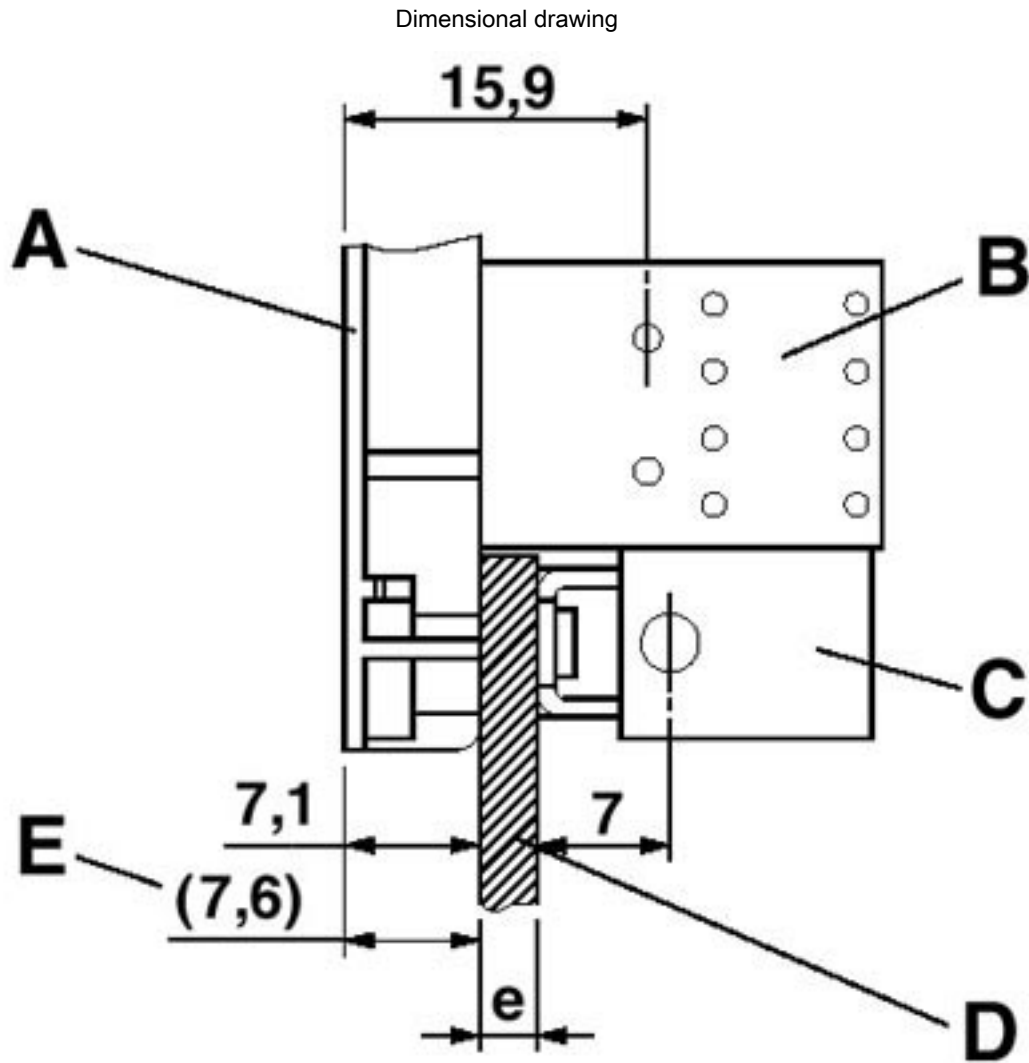

Installation, panel mounting flange

A = Panel mounting base

B = Solder-in contact insert

C = Mounting flange

D = Mounting panel $e = 1 \dots 5$ mm

E = Dimensions with EMC shield adapter mounted

Mounting flange - VC-AF - 1852862

Dimensional drawing

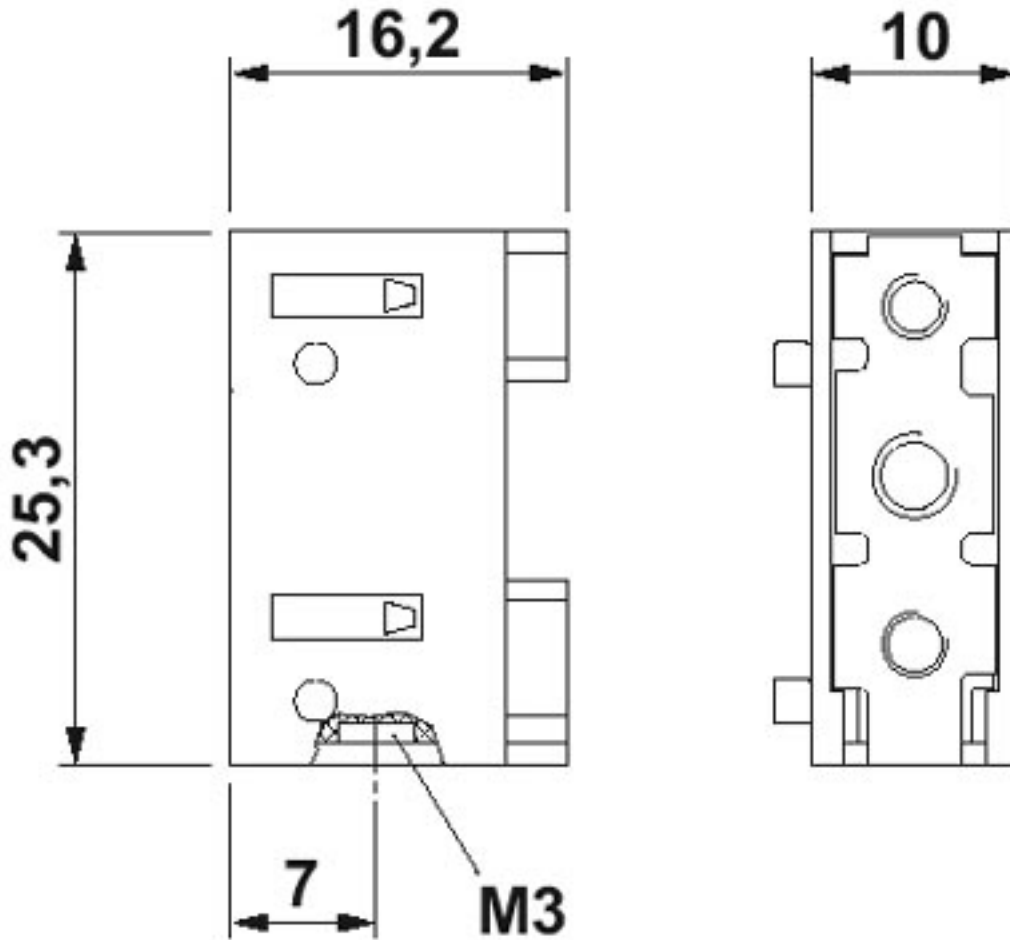

Mouser Electronics

Authorized Distributor

Click to View Pricing, Inventory, Delivery & Lifecycle Information:

[Phoenix Contact:](#)

[1852862](#)