

THIS DRAWING IS UNPUBLISHED. RELEASED FOR PUBLICATION 12, 2011.
 © COPYRIGHT 2011 By - ALL RIGHTS RESERVED.

LOC		DIST		REVISIONS			
P	LTR	DESCRIPTION		DATE	DWN	APVD	
GP	00	F	REVISED PER ECO-18-006244	24APR2018	AP	DG	

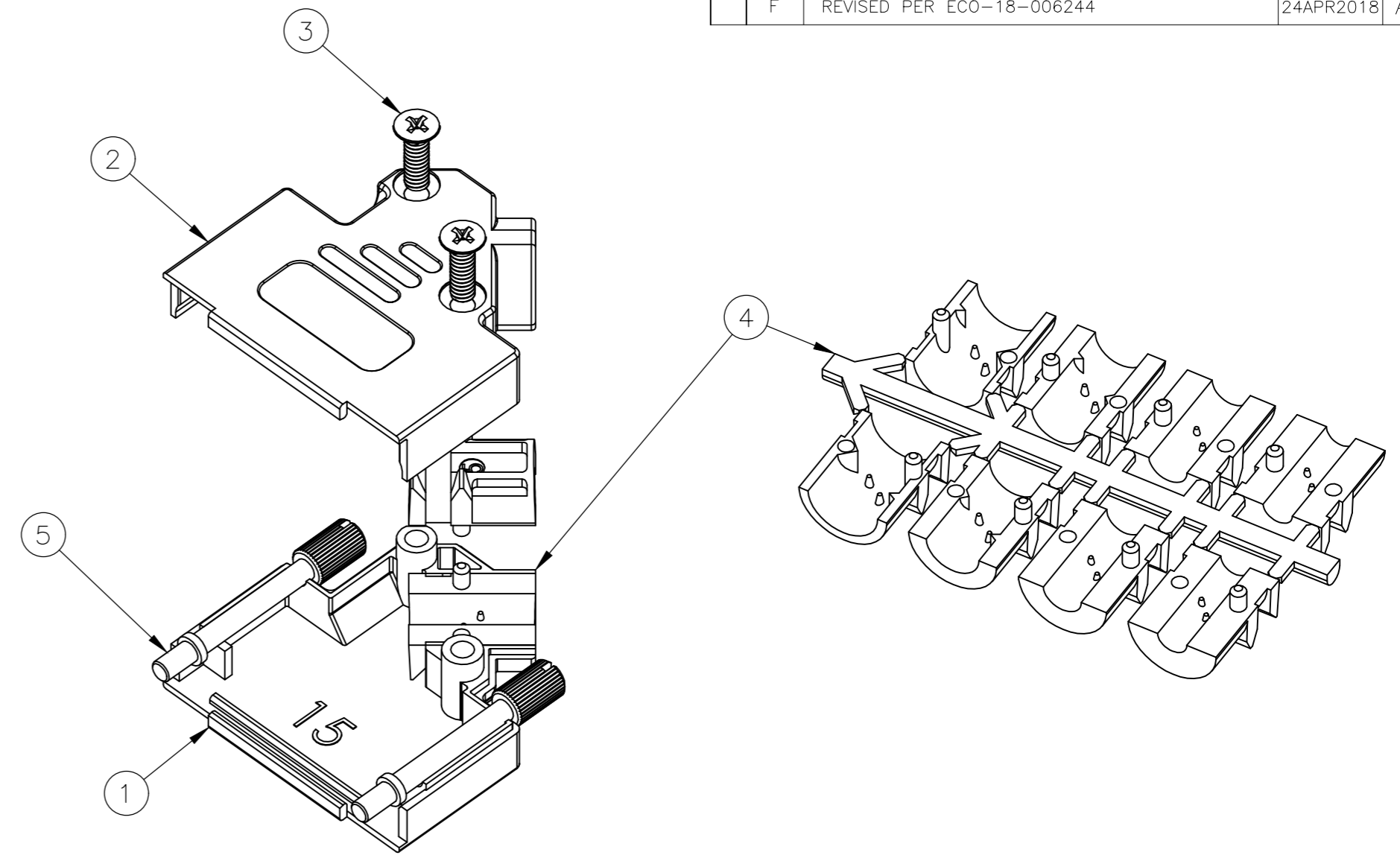
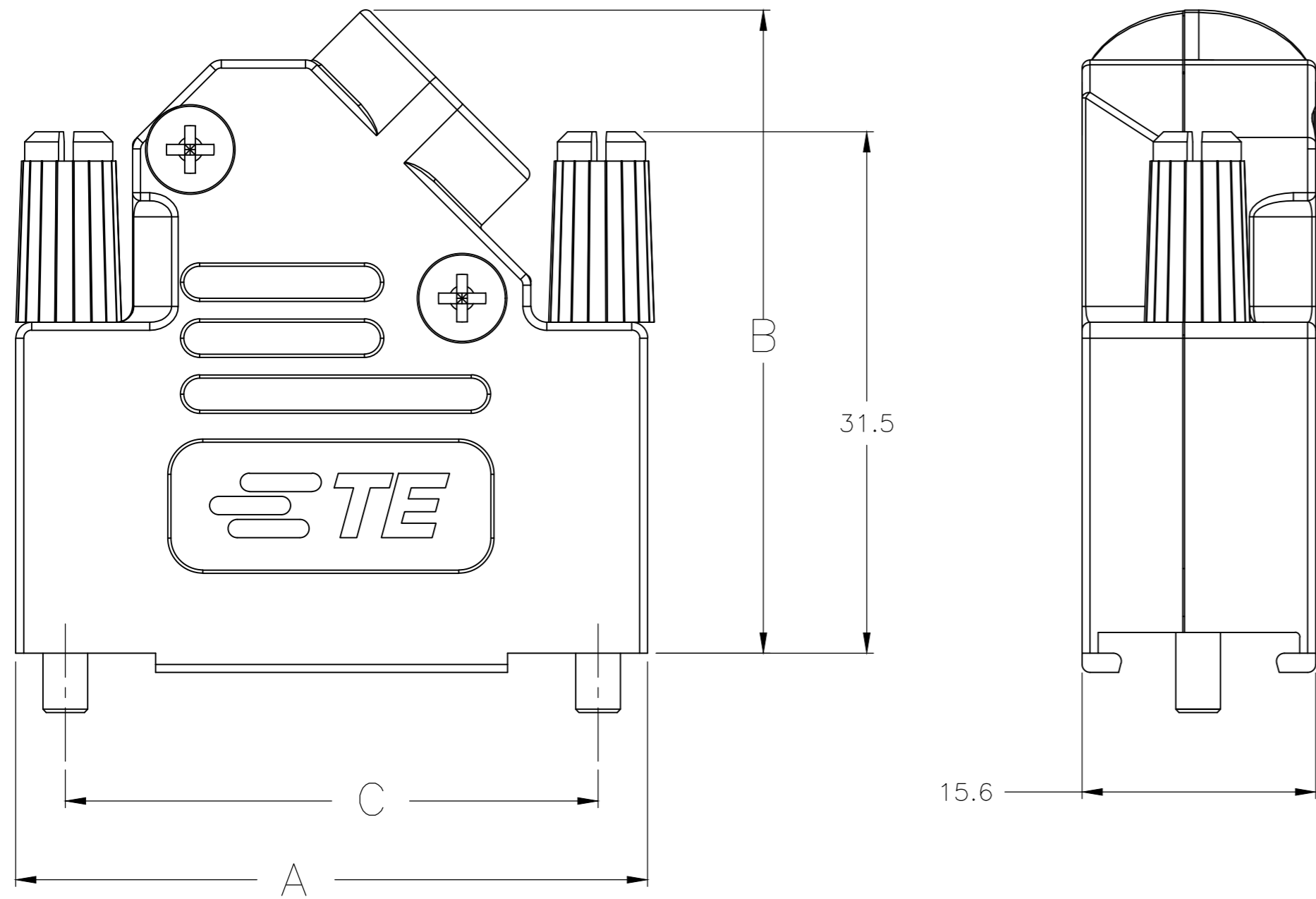

- 1. FOR ASSEMBLY DETAILS, REFER TO LEAFLET 2227518-1.
- 2. BULK PACKAGED BACKSHELL ASSEMBLIES: ITEMS 1 THRU 5, 100 TIMES QTY SHOWN IN TABLE IN 1 BAG FOR EACH ITEM. ALL BAGS IN 1 BOX WITH (1) 2227518-1 LEAFLET.
- 3. INDIVIDUALLY PACKAGED SHELL ASSEMBLIES: 1 BAG CONTAINS ALL COMPONENTS FOR 1 COMPLETE ASSEMBLY. 100 BAGS PER BOX, (1) 2227518-1 LEAFLET PER BOX.
- 4. TERMINATES 4.0-13.0 CABLE DIAMETERS.
- 5. 15 POSITION SHOWN.

- 6. TRIVALENT CHROMIUM CHROMATE COATING OVER ZINC PLATING.
- 7. JACKSCREW QUANTITY:
 9 WAY ASSEMBLY: 1 JACKSCREW
 15 WAY ASSEMBLY: 2 JACKSCREWS
 25 WAY ASSEMBLY: 2 JACKSCREWS
 37 WAY ASSEMBLY: 2 JACKSCREWS.
- 8. OPTIONAL CABLE CRIMP KIT AVAILABLE FOR 6.0-9.5 DIAMETER CABLE. SEE 1478764.

5	JACKSCREW ASSEMBLY, 4-40	POLYAMIDE, UL94 V2 KNOB	BLACK	7
		CARBON STEEL SHAFT	6	
4	STRAIN RELIEF SET	POLYCARBONATE UL94 V0	BLACK	1
3	SELF TAPPING FIXING SCREW	CARBON STEEL	6	2
2	TOP BACKSHELL	ABS UL94 V0	NICKEL	1
1	BOTTOM BACKSHELL	ABS UL94 V0	NICKEL	1
ITEM	DESCRIPTION	MATERIAL	FINISH	QTY

3	63.5	40.2	69.5	PHILLIPS	4-40 UNC	4	37 WAY	5-2198618-4
3	47.0	40.2	53.0	PHILLIPS	4-40 UNC	3	25 WAY	5-2198618-3
3	33.3	40.2	39.3	PHILLIPS	4-40 UNC	2	15 WAY	5-2198618-2
3	25.0	36.2	31.0	PHILLIPS	4-40 UNC	1	9 WAY	5-2198618-1
2	63.5	40.2	69.5	PHILLIPS	4-40 UNC	4	37 WAY	3-2198618-7
2	47.0	40.2	53.0	PHILLIPS	4-40 UNC	3	25 WAY	2-2198618-5
2	33.3	40.2	39.3	PHILLIPS	4-40 UNC	2	15 WAY	1-2198618-5
2	25.0	36.2	31.0	PHILLIPS	4-40 UNC	1	9 WAY	2198618-9
PACKAGING	C	B	A	SELF TAPPING FIXING SCREW TYPE	JACKSCREW THREAD	SHELL SIZE	POSITION	PART NUMBER

THIS DRAWING IS A CONTROLLED DOCUMENT. DIMENSIONING AND TOLERANCING PER ASME Y14.5M-2009

DWN: C. VALENTINE 09DEC2011
 CHK: C. ROHDE 08DEC2011
 APVD: C. ROHDE 08DEC2011

TE Connectivity

SHIELDED PLASTIC BACKSHELL 45 DEGREE ENTRY

SIZE: A2 CAGE CODE: 00779 DRAWING NO: C=2198618 RESTRICTED TO: -

MATERIAL: SEE TABLE FINISH: SEE TABLE WEIGHT: CUSTOMER DRAWING SCALE: 1:1 SHEET: 1 OF 1 REV: F

Mouser Electronics

Authorized Distributor

Click to View Pricing, Inventory, Delivery & Lifecycle Information:

[TE Connectivity:](#)

[2198618-9](#)