

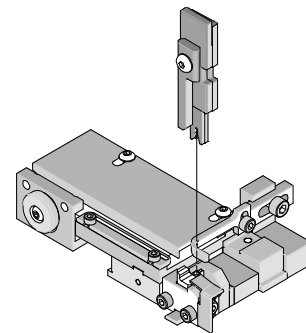

T2 Terminator Tooling Specification Sheet Part No. 63910-3500



FEATURES

- It is ideally suited for mid-volume bench operations
- This terminator can be installed in the TM42 and the TM40 press or Base Unit adapter for 3BF press
- Quick punch removal with the push of a button for fast and easy tooling change
- Track adjustment capabilities in the T2 Terminators for improved control of the bell mouth size and cutoff tab length
- T2 Terminator has standardized tooling with the Molex FineAdjust Applicator which will reduce your inventory requirements

SCOPE

Products: SL™ Crimp Terminal, Male, 22-24 AWG.

Terminal Series No.	Terminal Order No.			Wire Size		Insulation Diameter		Strip Length	
				AWG	mm ²	mm	In.	mm	In.
50088	50088-8000	50088-8060		22-24	0.35-0.20	1.00-1.60	.039-.063	3.00-3.50	.118-.138
	50088-8014	50088-8099							
	50088-8028								
70021	16-02-0081	16-02-0116	70021-0021	22-24	0.35-0.20	1.40-1.63	.055-.064	3.17-3.56	.125-.140
	16-02-0093	40-08-0874	70021-0023						
	16-02-0107	70021-0019	70021-0081						

DEFINITION OF TERMS

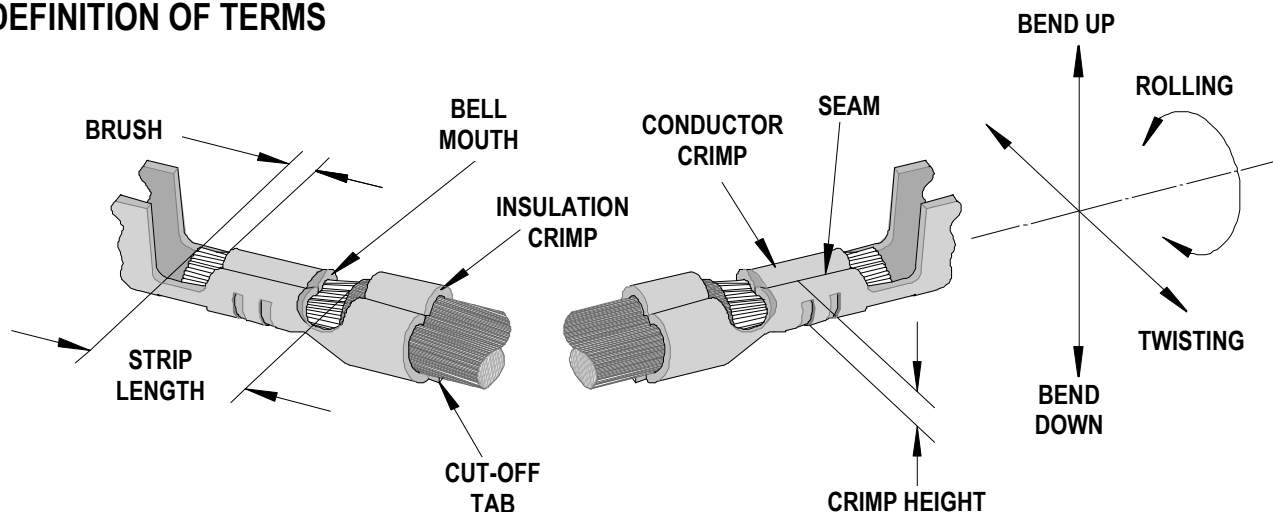

The above terminal drawing is a generic terminal representation. It is not an image of a terminal listed in the scope.

CRIMP SPECIFICATION

Terminal Series No.	Bell mouth		Cut-off Tab Maximum				Conductor Brush	
			Front		Rear			
	mm	In.	mm	In.	mm	In.	mm	In.
50088	0.20-0.50	.008-.020	0.15	.006	0.30	.012	0.00-1.00	.000-.039
70021	0.20-0.50	.008-.020	0.13	.005	0.13	.005	0.00-1.00	.000-.039

Terminal Series No.	Bend up	Bend down	Twist	Roll	Punch Width mm (Ref)				Seam Seam shall not be open and no wire allowed out of the crimping area
	Degree		Degree		Conductor		Insulation		
	mm	In	mm	In	mm	In	mm	In	
50088	3	3	3	8	1.40	.055	1.60	.063	
70021	3	3	3	8	1.40	.055	1.60	.063	

After crimping, the conductor profile should measure the following.

Terminal Series No.	Wire Size		Crimp Height		Pull Force Minimum	
	AWG	mm ²	mm	In.	N	Lb.
50088	22	0.35	0.84-0.89	.032-.035	39.1	8.8
	24	0.20	0.74-0.81	.029-.032	29.3	6.6
70021	22	0.35	0.84-0.89	.032-.035	35.6	8.0
	24	0.20	0.74-0.81	.029-.032	22.2	5.0

Pull Force should be measured with no influence from the insulation crimp.

The above specifications are guidelines to an optimum crimp.

PARTS LIST

T-Style Terminator 63910-3500				
Item	Order No	Engineering No.	Description	Quantity
Perishable Tooling				
	63910-3570	63910-3570	Tool Kit (All "Y" Items)	REF
1	63444-1417	63444-1417	Conductor Punch	1 Y
2	63445-1446	63445-1446	Conductor Anvil	1 Y
3	63446-1626	63446-1626	Insulation Punch	1 Y
4	63445-1630	63445-1630	Insulation Anvil	1 Y
5	63443-0003	63443-0003	Cut-Off Plunger	2 Y
6	63443-0012	63443-0012	Front Plunger Retainer	1 Y
7	63443-1402	63443-1402	Cut-off Die Blade	1 Y
8	63443-1002	63443-1002	Rear Plunger Retainer	1 Y
Other Components (REF 103450)				
9	11-17-0022	1739-21	Hold Down Spring	1
10	11-18-4083	60707-8	Feed Guide	1
11	11-24-1067	4996-4	Cut-Off Plunger Spring	2
12	11-40-4382	8341-8	Shank	1
13	11-40-4039	8302-5	Front Plunger Striker	1
14	63443-0025	63443-0025	Dual Carrier Key	1
15	63443-0085	63443-0085	Wire Stop L-Bracket	1
16	63443-0090	63443-0090	Wire Stop	1
17	63443-1718	63443-1718	18.80mm Height Spacer	1
18	63443-2204	63443-2204	4.00mm Coarse Spacer	1
19	63443-2310	63443-2310	3.50mm Fine Spacer	1
20	63443-6003	63443-6003	Rear Cover	1
21	63800-8502	63800-8502	Rear Plunger Striker	1
Frame				
22	63800-8500	63800-8500	T2 Terminator	1
Hardware				
23	N/A	N/A	M3 by 6 Long SHCS	2**
24	N/A	N/A	M3 by 6 Long FHCS	1**
25	N/A	N/A	M4 by 6 Long SHCS	1**
26	N/A	N/A	M4 by 12 Long BHCS	2**
27	N/A	N/A	M4 by 14 Long SHCS	2**
28	N/A	N/A	M4 by 35 Long SHCS	1**
29	N/A	N/A	M4 by 50 Long SHCS	1**
30	N/A	N/A	M5 by 10 Long SHCS	1**
31	N/A	N/A	M5 by 12 Long SHCS	1**
32	N/A	N/A	#10-32 by 3/8" Long BHCS	1**
** Available from an industrial supply company such as MSC (1-800-645-7270).				

Assembly Drawing

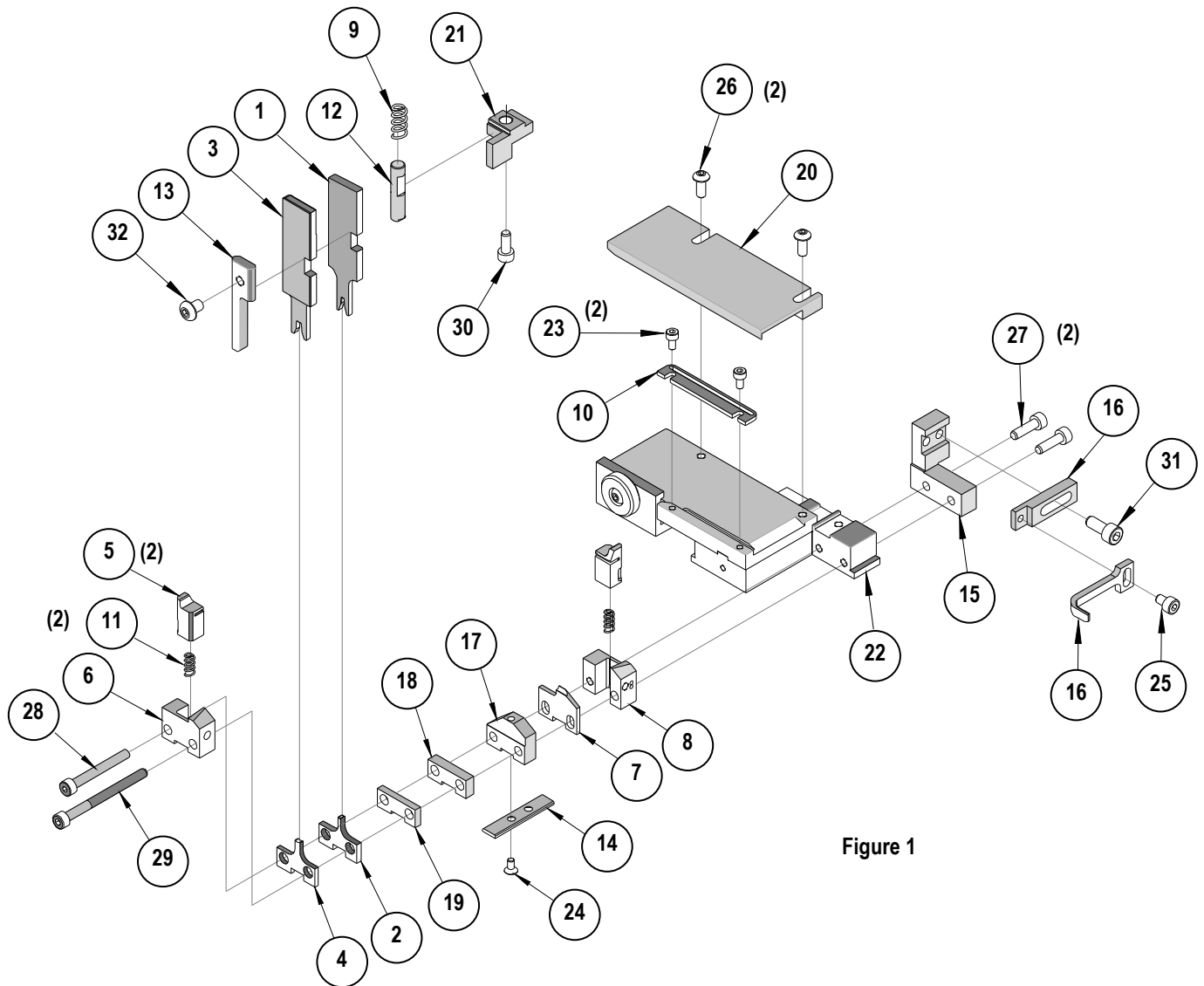
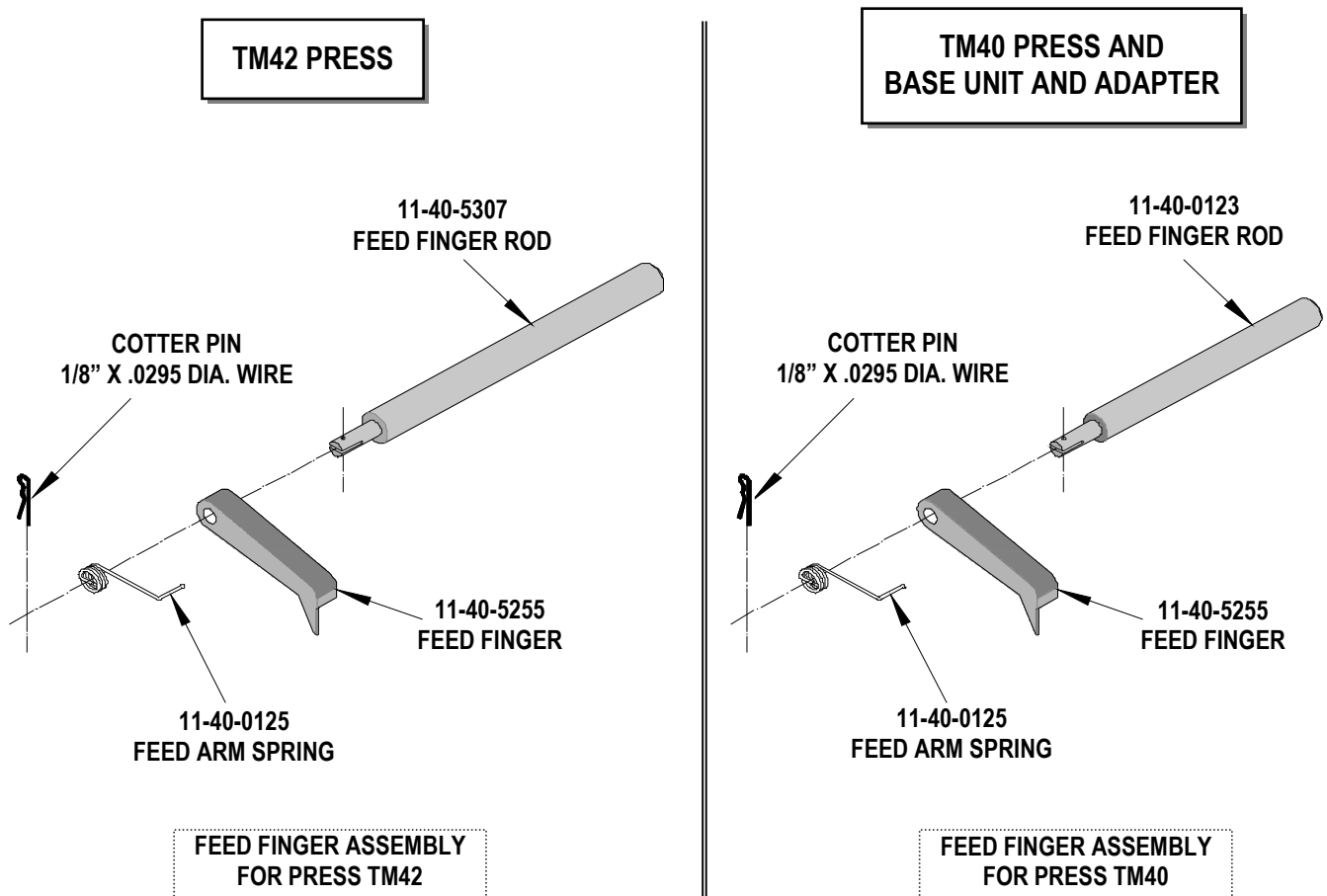

Figure 1

NOTES

Depending on the press vintage a feed finger assembly is supplied with the T2 Terminator.

1. To remove the existing feed finger assembly loosens the M4 x 10 mm set screw in the feed lever.
2. Select T2 Feed finger assembly from Terminator box.
3. Insert a screwdriver into the slot behind the feed lever and force the feed arm spring to the right.
4. Slide the T2 feed finger shaft for TM42 (11-40-5307) or (11-40-0123) for TM40 /Base Unit into the feed lever and to the left of the feed arm spring.
5. Release the feed arm spring.
6. Position feed finger for selected product. (Refer to Figure 5.1 in the T2 Manual).



NOTES

1. Molex recommends an extra perishable tooling kit be maintained at your facility.
2. Verify tooling alignment by manually cycling the press before crimping under power. Check that all screws are tight.
3. Slugs, Terminals, Dirt and Oil should be kept clear of work area.
4. This Terminator should be only used in a Molex TM42, TM40, or 3BF Press with a Base Unit adaptor.
5. Wear safety glasses at all times.
6. For recommended maintenance refer to the TM40, TM42 Manual.

CAUTION: To prevent injury never operate this Terminator without the guards supplied with the press or in place. Reference the TM42 press manufacturer's instruction manual.

CAUTION: Molex crimp specifications are valid only when used with Molex terminals, applicators and tooling.

Americas Headquarters
Lisle, Illinois 60532 U.S.A.
1-800-78MOLEX
amerinfo@molex.com

Far East North Headquarters
Yamato, Kanagawa, Japan
81-462-65-2324
feninfo@molex.com

Far East South Headquarters
Jurong, Singapore
65-6-268-6868
fesinfo@molex.com

European Headquarters
Munich, Germany
49-89-413092-0
eurinfo@molex.com

Corporate Headquarters
2222 Wellington Ct.
Lisle, IL 60532 U.S.A.
630-969-4550
Fax: 630-969-1352

Visit our Web site at <http://www.molex.com>

Mouser Electronics

Authorized Distributor

Click to View Pricing, Inventory, Delivery & Lifecycle Information:

[Molex:](#)

[63910-3570](#)