

Photoelectrics Amplifier Type S142C..

CARLO GAVAZZI



- μ -Processor controlled
- Amplifier relay for photoelectric switches
- Automatic or manual emitter power regulation
- Multiplex system, master/slave 20 ms cycle
- Self-diagnostic functions
- Alignment help
- Rated operational voltage:
24 VAC/DC, 115 VAC or 230 VAC
- Output 8 A/250 VAC SPDT relay
- LED indication: Automatic gain, output, level, emitter or receiver fault



Product Description

μ -Processor controlled amplifier for one set of photoelectric sensors, type MOFTR. Utilising an 11-pin circular plug for easy connection. 8 A SPDT relay output. Diagnostics for sensor test during operation. Alignment help via LED. Level indication for

dirt accumulation. Manual or automatic emitter power regulation. Master/ Slave system fully multiplexed for high neighbour immunity. Two emitter codes available for high neighbour immunity between two separate master/slave networks.

Ordering Key

S142 C RXM 924

Type _____
 Special function _____
 Output type _____
 R-Relay _____
 X-None _____
 M-Manuel adj. _____
 A-Manuel and automatic adj. _____
 Power supply _____

Type Selection

Function	Ordering no. Supply: 24 VAC/DC	Ordering no. Supply: 115 VAC	Ordering no. Supply: 230 VAC
Manuel or Automatic adj. ¹⁾	S142 C RXA 924	S142 C RXA 115	S142 C RXA 230
Manuel adj. ²⁾	S142 C RXM 924	S142 C RXM 115	S142 C RXM 230

¹⁾ Amplifier can not be used as replacement in old systems, if used in old systems all amplifiers must be replaced.

²⁾ Amplifier direct replacement for S1423156xxx, only for replacement not for new design.

Specifications

Rated operational voltage (U_B) Pins 2 & 10	230 115 924	195 to 265 VAC, 45 to 65 Hz 98 to 132 VAC, 45 to 65 Hz 20.4 to 27.6 VAC/DC Class 2	Receiver Supply voltage (open loop) Short-circuit current Input resistance	Pins 6 & 8 5 VDC 10 mA 470 Ω
Rated operational power AC supply AC/DC supply	3.3 VA 1.6 VA / 1.4 W		Emitter power Power	Settings on DIP switch no 4, 50 % or 100 % range
Delay on operate (t_v)	< 300 mS		Sensitivity adjustment Manual Automatic /Auto LED ON)	240° Potentiometer Potentiometer settings fully counter clockwise
Outputs Relay Rating (AgCdO) Resistive loads	AC1 DC1 or AC1	μ (micro gap) 8 A / 250 VAC (2500 VA) 0.2 A / 250 VDC (50 W) 2 A 25 VDC (50 W) > 100.000 operations	Max. sensing distance	Maximum range indicated on photoelectric switch data- sheets in 100 % settings
Output function Relay	Make or break on DIP-switch SPDT		Rated insulation voltage (U_i)	250 VAC
Supply to sensors Emitter Supply voltage (open loop) Current	Pins 5 & 7 15 V square wave < 450 mA, short circuit protected		Dielectric voltage	>2.0 KVAC (rms) (contacts / electronics)
Output resistance	10 Ω		Rated impulse withstand volt.	4 kV (1.2/50 μ S) (contacts / electronics) (IEC 664)
			Operating frequency (f) Light / Dark ratio Relay output	1:1 20 HZ

Specifications

Response time OFF-ON (t_{ON}) ON-OFF (t_{OFF})	20 mS x no. of systems 20 mS x no. of systems	Housing material	NORYL SE1, light grey
Environment Overvoltage category Degree of protection Pollution degree	III (IEC 60664) IP 20 /IEC 60529, 60947-1) 3 (IEC 60664/60664A, 60947-1)	Weight AC supply AC/DC supply	200 g 125 g
Temperature Operating Storage	-20° to +50°C (-4° to +122°F) -50° to +85°C (-58° to +185°F)	Approvals CE marking	UL508, UL325, CSA EN12445, EN12453, EN12978

Specifications

Diagnostic

If a fault occurs on either the emitter or receiver the Alarm LED and output will turn ON.

Receiver fault

During normal operation the receiver is monitored for faults.

If the wires are short-circuited the "Code A, Yellow LED" flashes at a rate of 2 Hz.

If the wires are broken the "Code A, Yellow LED" flashes at a rate of 4 Hz.

Emitter fault

During normal operation the emitter is monitored for faults.

If the wires are short-circuited the "Code B, Green LED"

flashes at a rate of 2 Hz.

If the wires are broken the "Code B, Green LED" flashes at a rate of 4 Hz.

Alignment

If the alignment DIP switch is set the Yellow Signal LED Flashes according to the signal quality.

Low frequency means weak signal.

Steady indication means maximum signal. On long distance it is not possible to get a steady signal but the alignment is optimal when the led flashes with the highest frequency.

On short distance the sensitivity can be reduced using the potentiometer and then

get better readings in the alignment LED.

The ALARM output will follow the Signal LED in alignment mode, so a Sensor tester (optional) can be connected to serve as a remote indication during alignment of the sensors.

NB! In alignment mode the output is off.

Code A or B

When two sensor pairs are mounted close to each other it is recommended to select one set to Code A and the other to Code B to minimize crosstalk.

Dirt reserve

For optimal detection excess gain settings can be selected using the Level Low/High DIP switch:

- High: Allows high dirt build-up.
- Low: Allows detection of semi-transparent objects.

Power settings

To avoid a too strong emitter the power can be reduced to 50% reducing the max distance to 25%

Operation Diagram

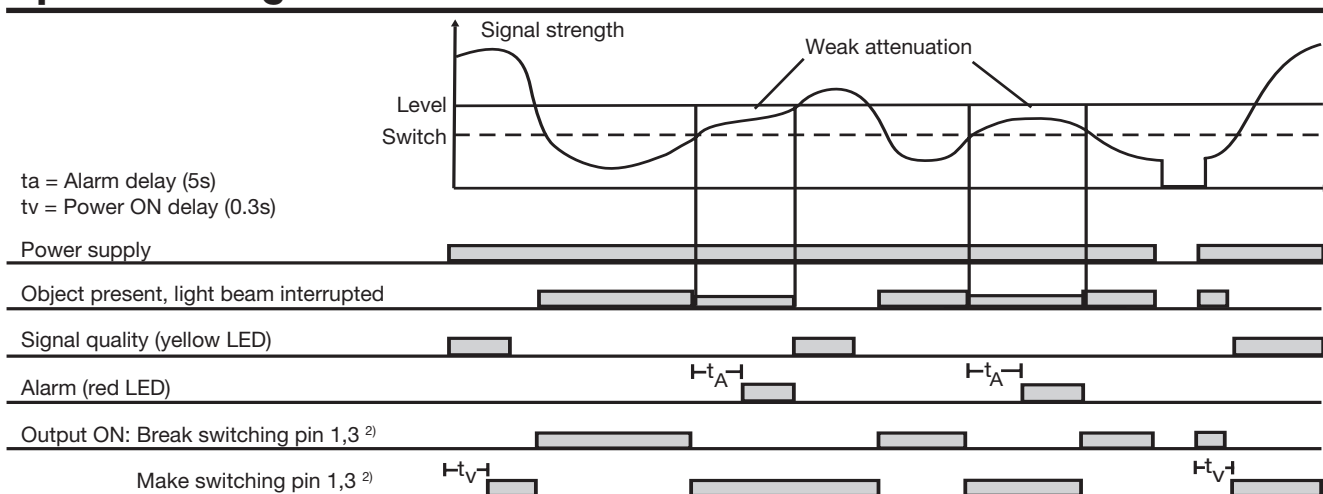

²⁾ Switching function selected by DIP-switch, inverted function on pin 1, 4

Mode of Operation

A multiplexed system consists of 1 master amplifier which initialises the multiplex cycle with a trigger signal, and up to 10 slave amplifiers connected together in a loop via the trigger signal. Pin 9 (trig-

ger signal out) to pin 11 (trigger signal in). The multiplex cycle is reinitialized automatically by the master each 350 ms or, immediately after the last slave amplifier in the loop has been activated, if the trig-

ger output of the last slave amplifier is connected to the trigger input of the master. Each photoelectric switch has its own amplifier with a relay output. A multiplexed system allows the use of up to

11 long range photoelectric switches mounted near one another, without having false output signals due to optical crosstalk.

Dimensions

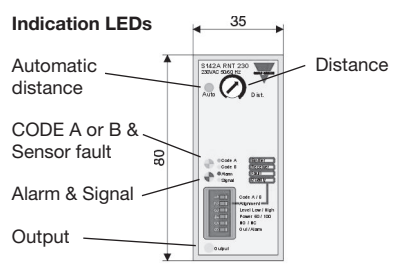

Indication LEDs

- Automatic distance
- CODE A or B & Sensor fault
- Alarm & Signal
- Output

Dimensions: 35 (width), 80 (height), 81.5 (total width), 75 (main body width), 4 (left offset), 2.5 (right offset).

DIP Switches

- 1 Code: A B
- 2 Alignment: ON OFF
- 3 Level: Low High
- 4 Power: 50% 100%
- 5 Output All: NC NO
- 6 Output 9: Master Slave

ON OFF

Wiring Diagrams

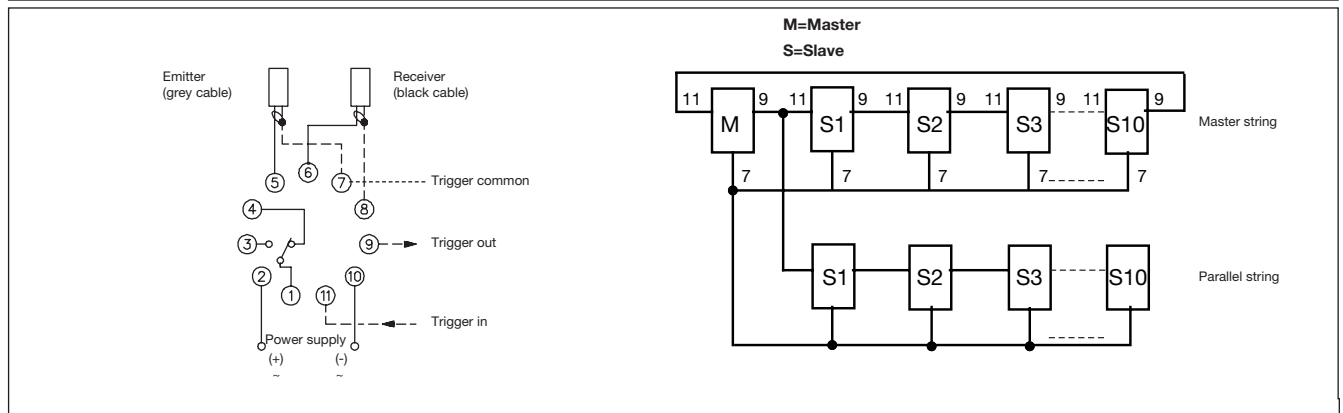

Accessories

- 11 pole circular socket ZPD11
- Holding down spring HF
- Mounting rack SM13
- Front panel mounting bezel FRS2

Delivery Contents

- Amplifier
- **Packaging:** Carton box

Master string A

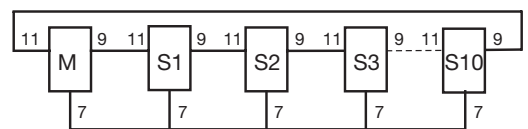

Master string B

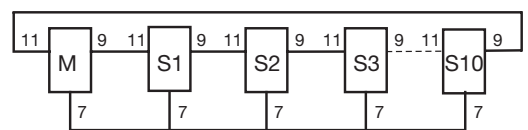

When mounted close together select two codes A or B to increase neighbour immunity

Mouser Electronics

Authorized Distributor

Click to View Pricing, Inventory, Delivery & Lifecycle Information:

[Carlo Gavazzi:](#)

[S142CRXM230](#) [S142CRXM115](#) [S142CRXA115](#) [S142CRXA230](#) [S142CRXM924](#) [S142CRXA924](#)