

THIS DRAWING IS UNPUBLISHED. RELEASED FOR PUBLICATION  
 © COPYRIGHT - By - ALL RIGHTS RESERVED.

REVISIONS					
P	LTR	DESCRIPTION	DATE	DWN	APVD
	H	ECR-16-013297	21JUL2017	FL	SY

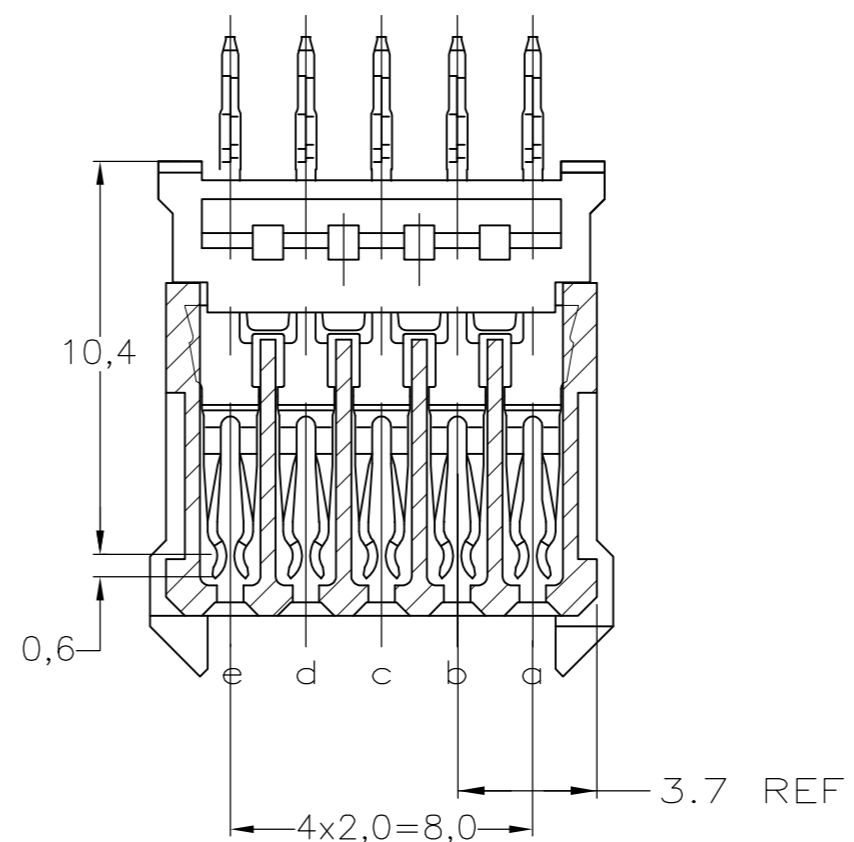

SECTION A-A

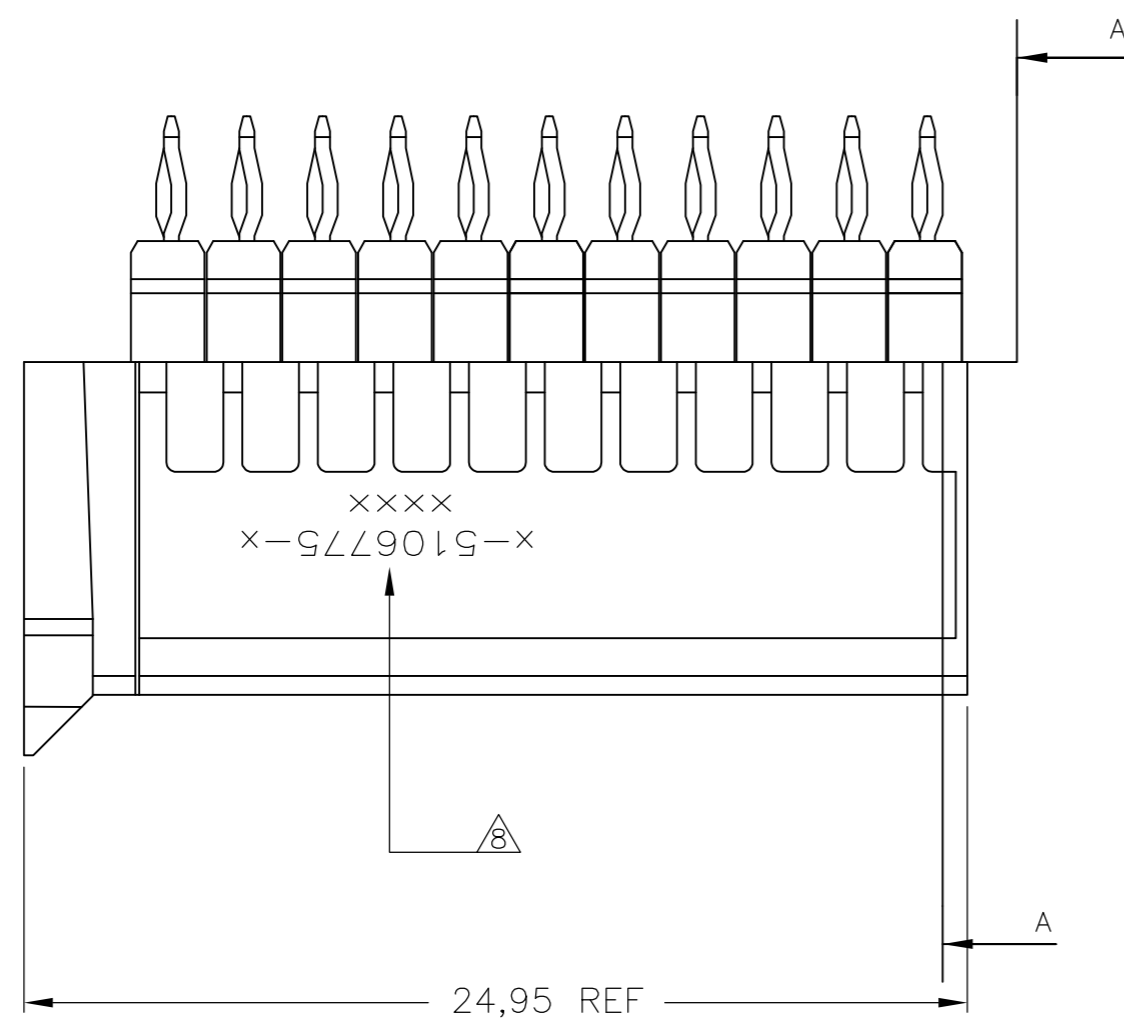
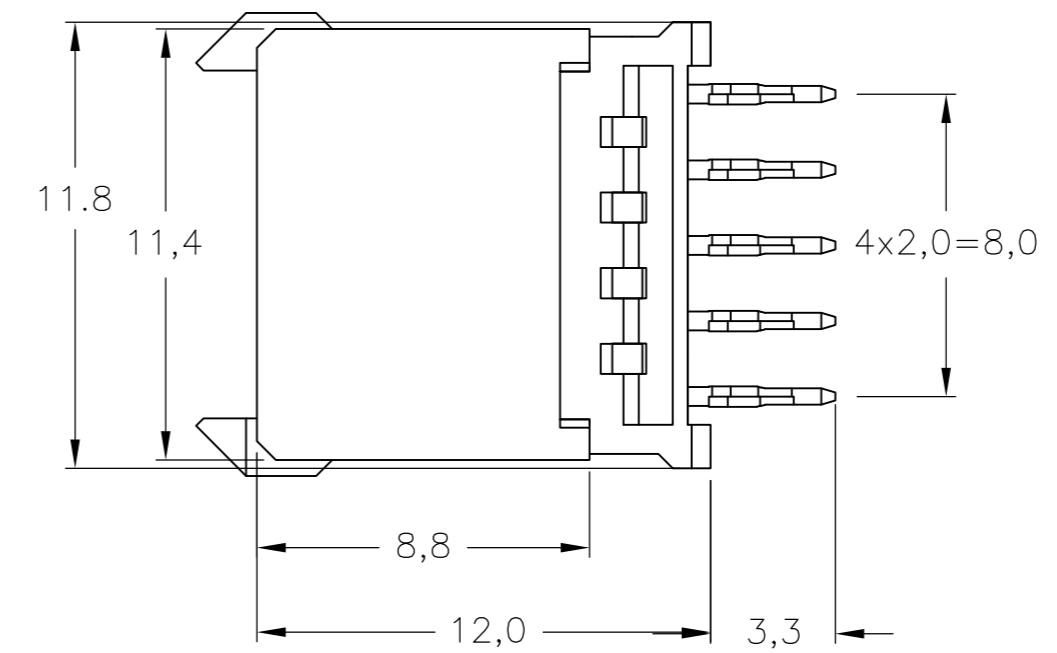
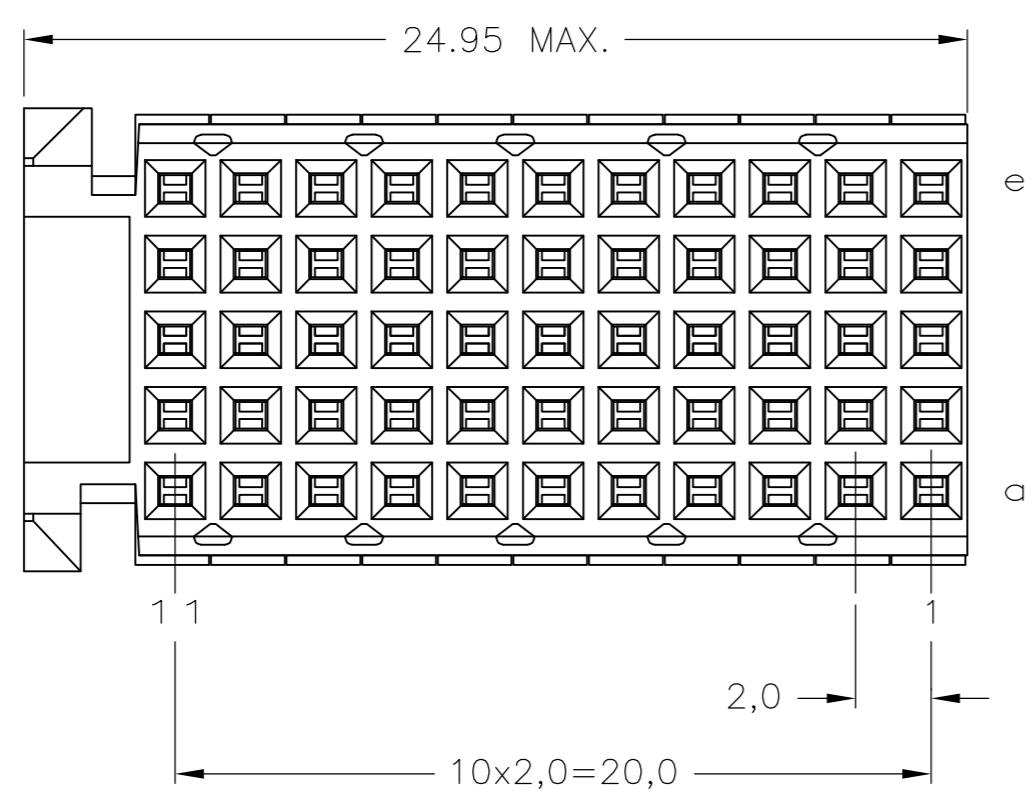

NOTES:

- ⚠ MATERIAL CONTACT: PHOSPHORBRONZE  
MATERIAL HOUSING: GLASSFILLED POLYESTER  
UL-RATING 94V0 (GRAY).
- ⚠ GENERAL PLATING SPECIFICATION: UNDERPLATING (ENTIRE CONTACT):  
1,27µm NICKEL MIN. AND ACTION PIN: 0,5µm TIN MIN.  
FOR PLATING OF MATING SURFACES SEE APPLICABLE  
SPECIFICATION REFERENCE FOR EACH DASH NUMBER.
- ⚠ CONFORMS TO ALL TESTING ACCORDING IEC 61076-4-101  
PERFORMANCE LEVEL 2.
- ⚠ CONFORMS TO ALL TESTING ACCORDING IEC 61076-4-101  
PERFORMANCE LEVEL 1.
- ⚠ CONNECTOR TESTED AND QUALIFIED AGAINST TELCORDIA GR-1217-CORE  
QUALITY LEVEL III, CENTRAL OFFICE APPLICATIONS.
- ⚠ CONNECTOR TESTED AND QUALIFIED AGAINST TELCORDIA GR-1217-CORE  
QUALITY LEVEL III, UNCONTROLLED ENVIRONMENT APPLICATIONS.
- ⚠ CONNECTOR LUBRICATED WITH TELCORDIA GR-1217-CORE  
APPROVED LUBRICANT.
- ⚠ CONNECTOR PRINTED WITH PARTNUMBER AND DATECODE.
- ⚠ PLATED-THROUGH HOLES AT 2x2mm SQUARE GRID (55 HOLES).
- ⚠ HOLES IN ROW f AND z FOR POSSIBLE FUTURE USE OF  
GROUND RETURN SHIELD. (SHIELDS NOT YET TOOLED)
- ⚠ 0.76µm MIN. GOLD PLATING AT MATING SURFACE

P.C.B. HOLE DIM. ACTION PIN  
 FOR DETAILS SEE  
 APPLICATION SPECIFICATION

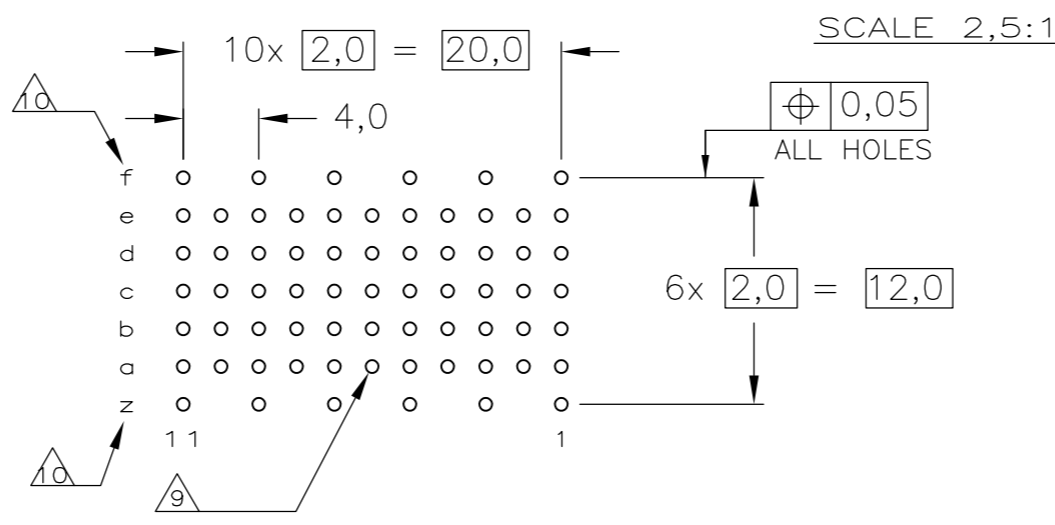

COMPONENT SIDE AS SHOWN  
 RECOMMENDED PCB-HOLE LAY-OUT

	⚠⚠⚠	⚠	3-5106775-0
OBSOLETE	⚠⚠⚠	⚠	1-5106775-9
OBSOLETE	⚠⚠⚠	⚠	5106775-9
OBSOLETE	⚠⚠⚠	⚠	5106775-4
	⚠⚠⚠	⚠	5106775-1
	FINISH	MATERIAL	PARTNUMBER

THIS DRAWING IS A CONTROLLED DOCUMENT.		DWN	13AUG2004	 TE Connectivity
DIMENSIONS: mm		CHK	27OCT2004	
TOLERANCES UNLESS OTHERWISE SPECIFIED:		APVD	27OCT2004	
0-PLC ± - 1-PLC ± - 2-PLC ± - ±0.2 3-PLC ± - 4-PLC ± - ANGLES ± - FINISH		NAME		
MATERIAL		APPLICATION SPEC 108-19082 114-19029		Z-PACK 2mm HM TYPE C 55 POS. VERTICAL FEMALE CONNECTOR ASSEMBLY
WEIGHT		0.00000	SIZE	A2
CUSTOMER DRAWING		CAGE CODE	00779	DRAWING NO
SCALE		5:1	SHEET	1 of 1
REV		H	RESTRICTED TO	