

Product data sheet

Characteristics

XZCC12FCM50B

female, M12, 5-pin, elbowed connector - cable gland Pg 7

Product availability: Non-Stock - Not normally stocked in distribution facility

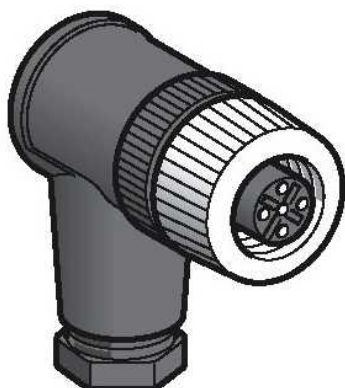

Main

Commercial Status	Commercialised
Accessory / separate part category	Cabling accessories
Accessory / separate part type	Connector
Electrical connection	Elbowed female connector M12, 5 pins
Collar material	Metal
Status LED	Without
Cable connection	Screw terminal / wire size $\leq 0 \text{ in}^2 (0.75 \text{ mm}^2)$ / clamping capacity 0.12...0.24 in (3...6 mm)

Complementary

Cable gland type	Pg 7
Cable connector fixing	Screw-on
[Ue] rated operational voltage	36 V DC 30 V AC
[In] rated current	3 A
Enclosure material	Plastic
Insulating resistance	$> 1000 \text{ G}\Omega$
Contact resistance	$\leq 8000 \mu\text{Ohm}$
Product weight	0.04 lb(US) (0.02 kg)

Environment

IP degree of protection	IP67
Ambient air temperature for operation	-40...185 °F (-40...85 °C)

Ordering and shipping details

Category	22483 - MACHINE CABLES
Discount Schedule	DS3
GTIN	003389110806267
Nbr. of units in pkg.	1
Package weight(Lbs)	0.07
Product availability	Non-Stock - Not normally stocked in distribution facility
Returnability	Y
Country of origin	DE

Offer Sustainability

Sustainable offer status	Not Green Premium product
RoHS	Compliant - since 0726 - Schneider Electric declaration of conformity

Contractual warranty

Period	18 months
--------	-----------

Mouser Electronics

Authorized Distributor

Click to View Pricing, Inventory, Delivery & Lifecycle Information:

[Schneider Electric:](#)

[XZCC12FCM50B](#)