

REVISIONS					
P	LTR	DESCRIPTION	DATE	DMN	APVD
V	REV PER ECO	17-000132	5-5-17	CT	DM

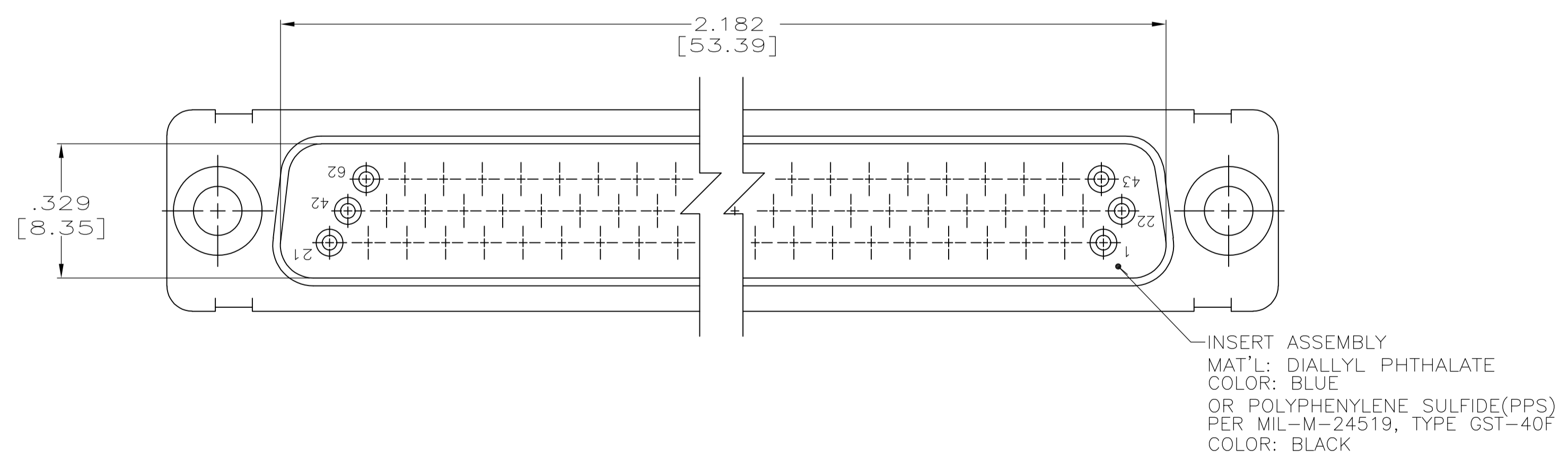

- CONTACTS INCLUDED IN ASSEMBLY.
- MATL: STEEL, PER ASTM-A-109.
- FINISH: CADMIUM PER QQ-P-416.
- MATL: BRASS PER ASTM-B-36.
- FINISH: PLATED ZINC .00020 MIN THK PER ASTM-B-633. YELLOW CHROMATE FINISH.
- CONTACT
 BODY MAT'L: BERYLLIUM COPPER PER ASTM-B-197.
 BODY FINISH: PLATED GOLD, .000050 MIN THK PER MIL-G-45204 OVER NICKEL, .000050 MIN THK PER QQ-N-290.
 HOOD MAT'L: STAINLESS STEEL PER ASTM-A-240.
 HOOD FINISH: PASSIVATED PER QQ-P-35
- FINISH: PLATED GOLD, .000050 MIN THK PER MIL-G-45204 OVER COPPER FLASH
- FINISH: PLATED GOLD, .000050 MIN THK PER MIL-G-45204 OVER COPPER, .000100 MIN THK PER MIL-C-14550.
- CONTACT
 BODY MAT'L: BERYLLIUM COPPER PER ASTM-B-197.
 BODY FINISH: PLATED GOLD, .000050 MIN THK PER MIL-G-45204 OVER COPPER, .000100 MIN THK PER MIL-C-14550.
 HOOD MAT'L: COPPER ALLOY PER QQ-B-613.
 FINISH: PLATED GOLD, .000050 MIN THK PER MIL-G-45204 OVER COPPER, .000100 MIN THK PER MIL-C-14550.

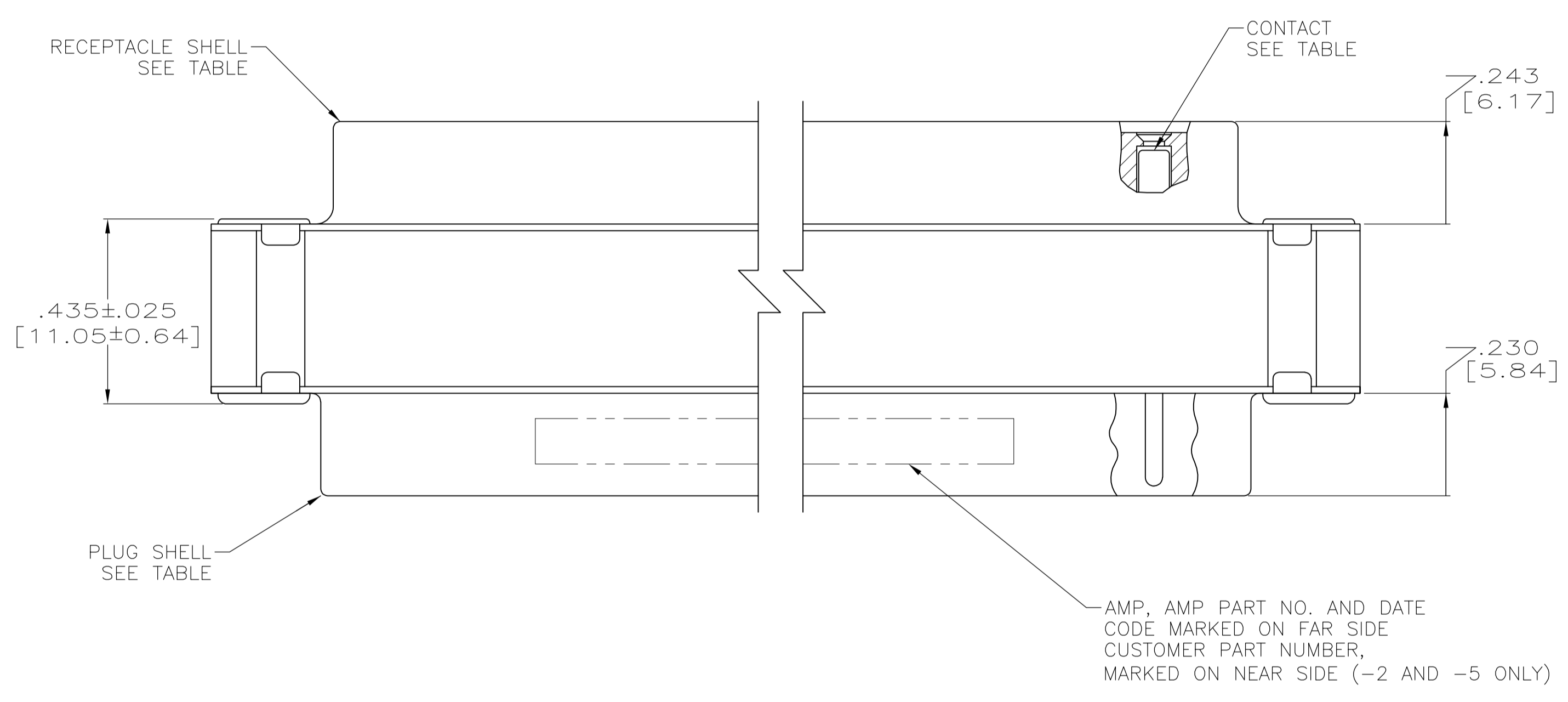
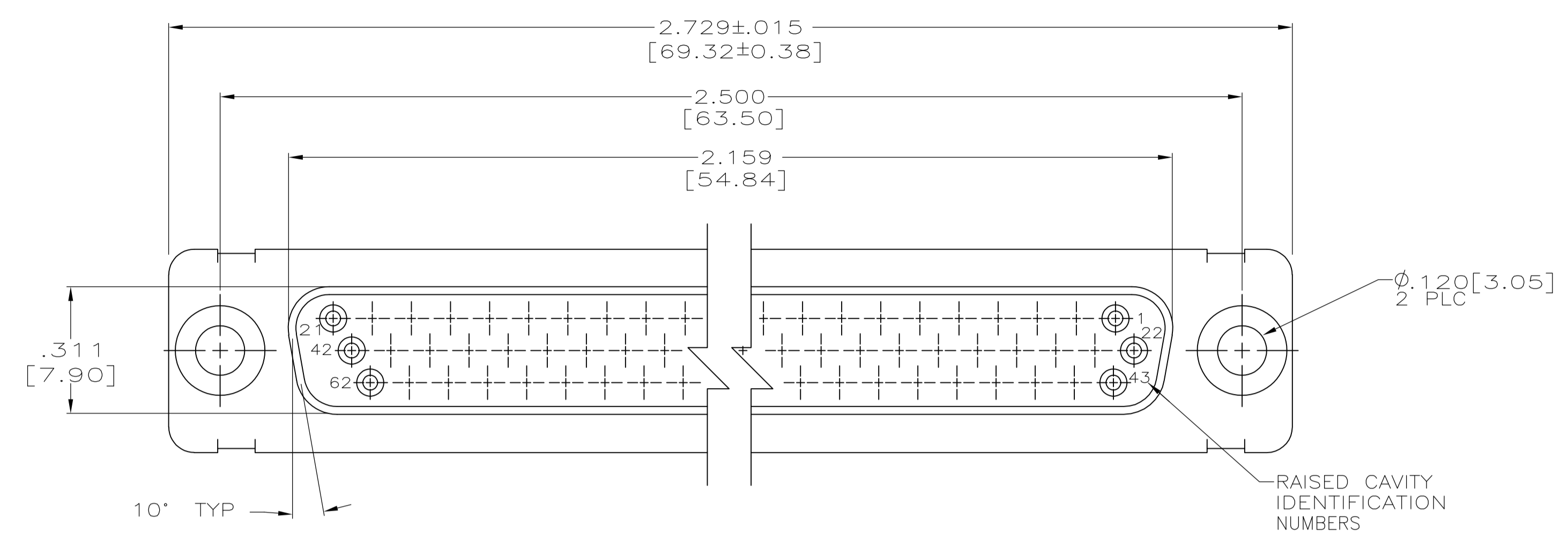
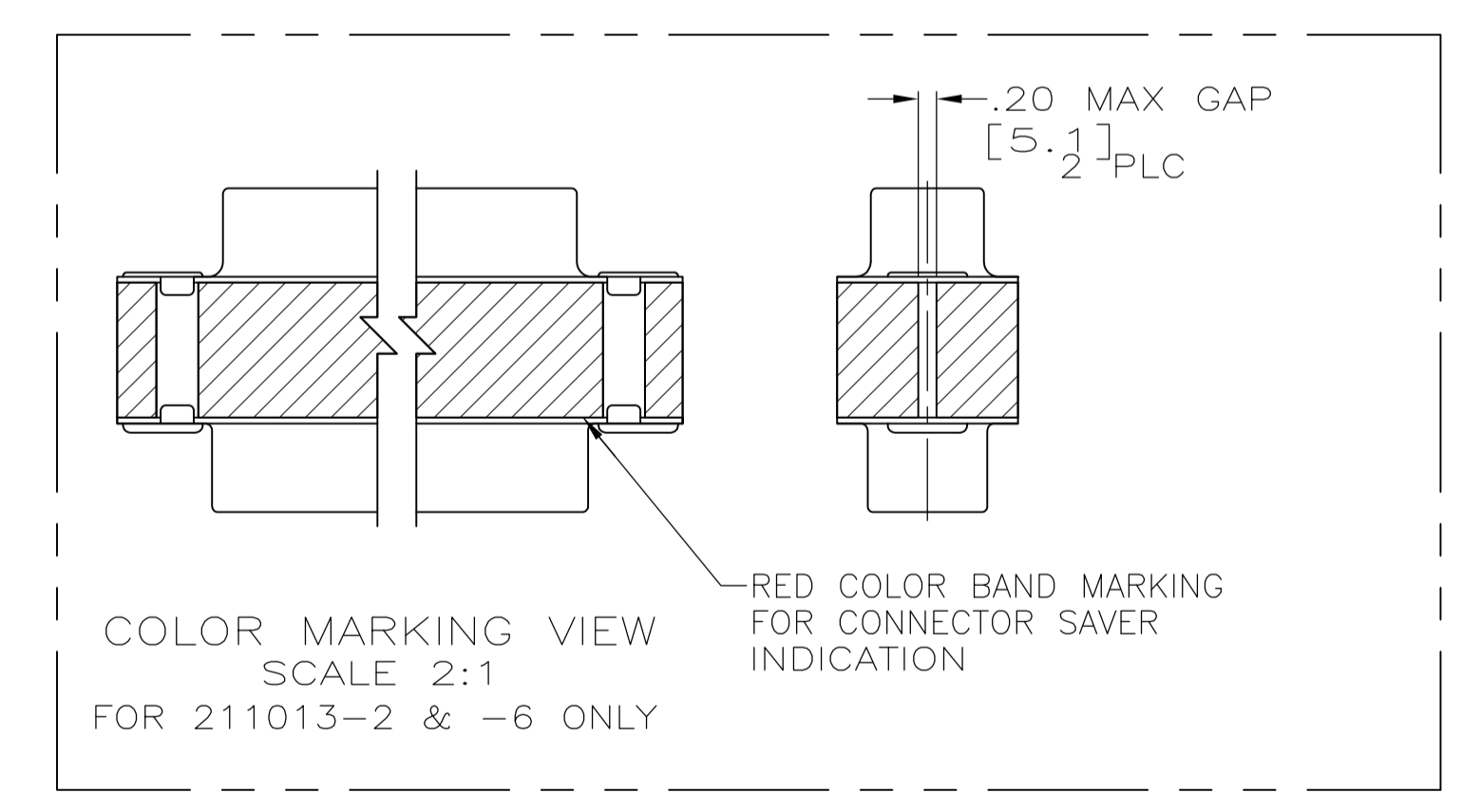
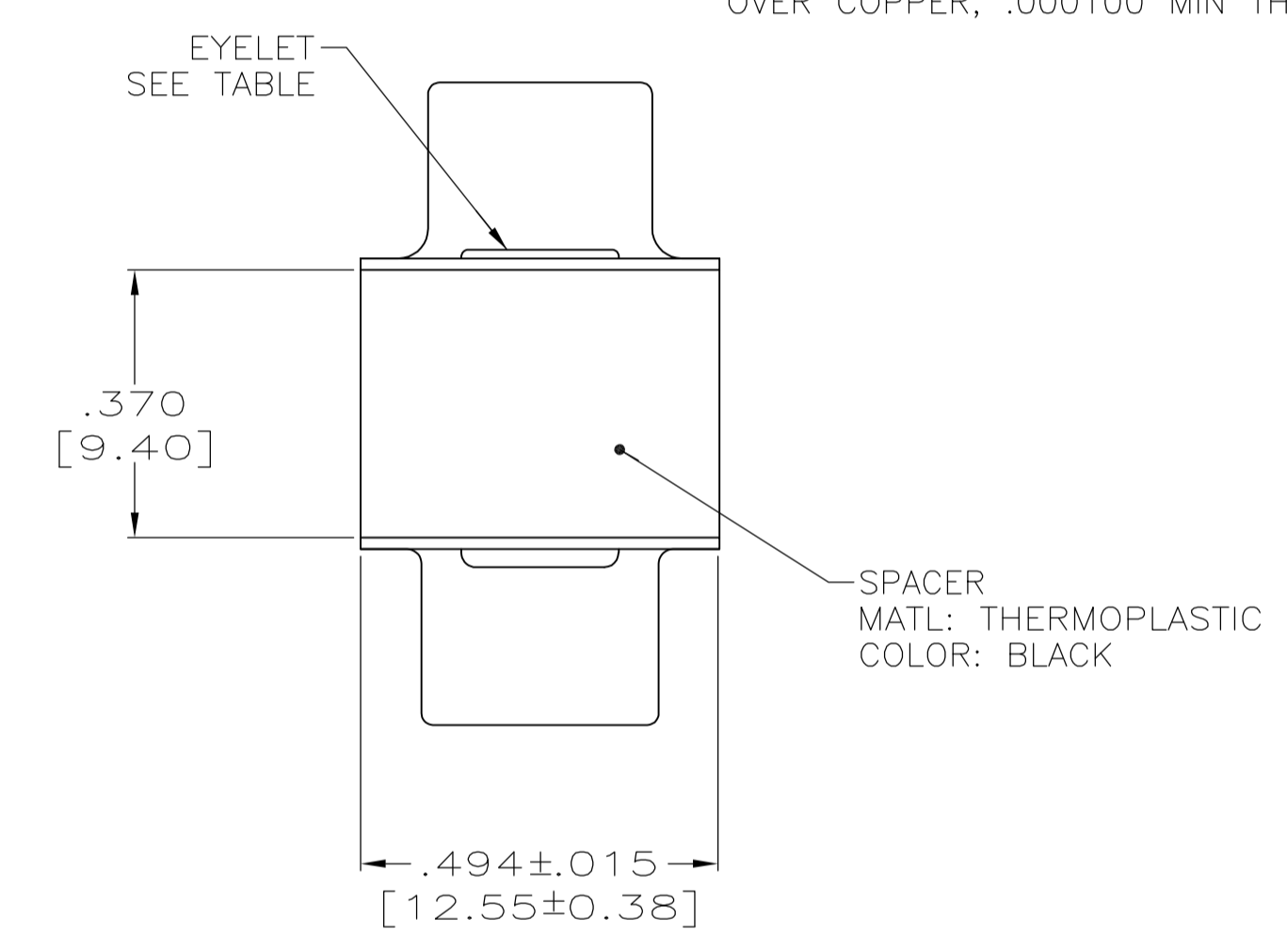

△ △	△ △	△	R10002677-0109	211013-6
△ △	△ △	△	2A091-004W-001	211013-5
△ △	△ △	△	-	211013-4
△ △	△ △	△	(1J02-109)	211013-2
△ △	△ △	△	-	211013-1
EYELET	SHELLS	CONTACT	CUSTOMER P/N	PART NO.

THIS DRAWING IS A CONTROLLED DOCUMENT. DIM C.C.THOMAS 11-3-98
 DIM J.NORTON 11-17-98
 DIM J.NORTON 11-17-98

TE Connectivity
 CONNECTOR SAVER,AMPLIMITE
 62 POSN.,SIZE 4,SERIES 90

APVD J.NORTON 11-17-98
 PRODUCT SPEC
 APPLICATION SPEC

SIZE A1 CAGE CODE 00779 DRAWING NO. 211013
 WEIGHT 0
 CUSTOMER DRAWING SCALE 4:1 SHEET 1 OF 1 REV V

Mouser Electronics

Authorized Distributor

Click to View Pricing, Inventory, Delivery & Lifecycle Information:

[TE Connectivity:](#)

[211013-4](#)