

Customer Information Sheet

DRAWING No.: M22-714XX42

IF IN DOUBT - ASK

Ⓒ

NOT TO SCALE

THIRD ANGLE PROJECTION

ALL DIMENSIONS IN mm

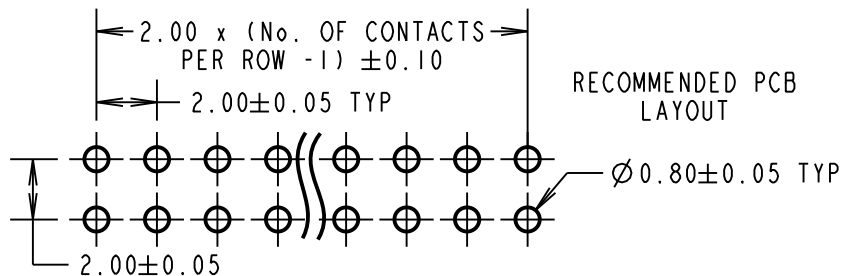

ORDER CODE:

M22-714XX42

No. OF CONTACTS PER ROW:
03 TO 25

FINISH:
42 = GOLD FLASH ON CONTACT,
100% TIN ON TAILS

SPECIFICATION:

MATERIAL:

MOULDING = LCP UL94V-0, BLACK
CONTACTS = PHOSPHOR BRONZE

FINISH: (OVER NICKEL)

42 = 0.76 - 1.27µ NICKEL ALL OVER,
GOLD ON CONTACT AREA,
2.54µ 100% TIN ON TAILS

MECHANICAL:

DURABILITY = 5000 CYCLES MAX
INSERTION FORCE = 2N MAX PER PIN
WITHDRAWAL FORCE = 0.2N MIN PER PIN

ELECTRICAL:

CURRENT RATING = 2A AC/DC
CONTACT RESISTANCE = 20mΩ MAX
INSULATION RESISTANCE = 5000MΩ MIN
DIELECTRIC WITHSTANDING = 500V AC FOR 1 MIN

ENVIRONMENTAL:

TEMPERATURE RANGE = -40° TO +105°

PACKING:

TUBE

FOR COMPLETE SPECIFICATION SEE COMPONENT SPECIFICATION C018XX (LATEST ISSUE)

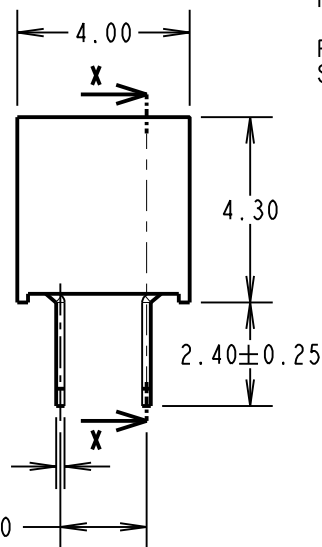
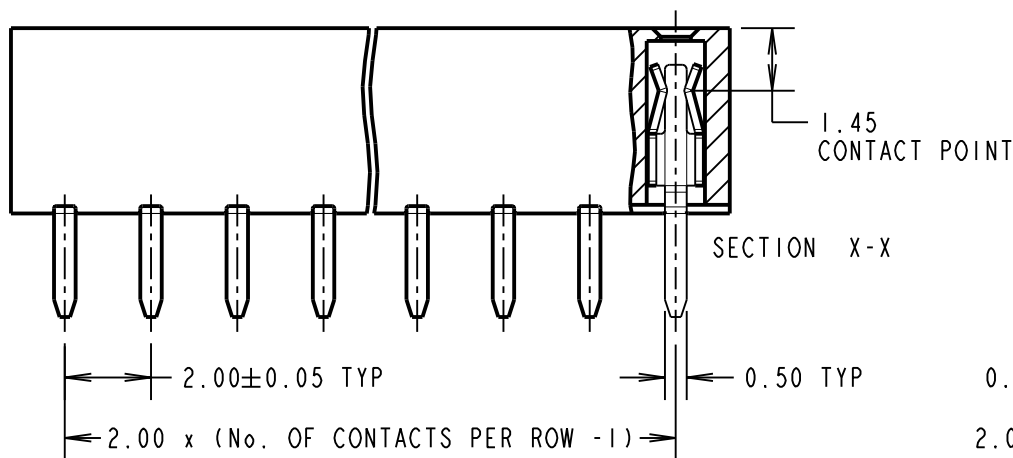
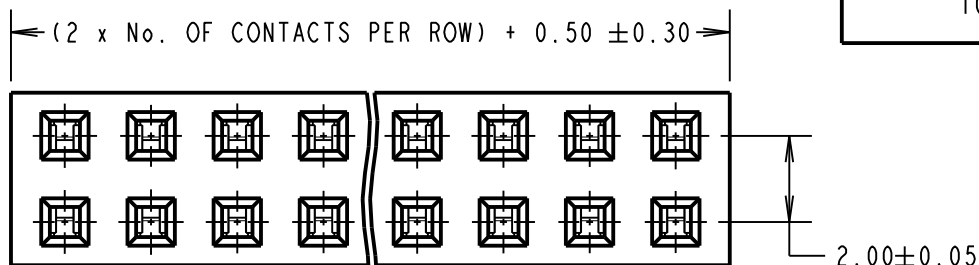

NOTE:

1. ALL TOLERANCES ARE ±0.15,
UNLESS OTHERWISE STATED.

MSP	10	26.10.16	13421
NAME	ISS.	DATE	C/NOTE
APPROVED:		M.PERREN	
CHECKED:		S.BENNETT	
DRAWN:		J. EVANS	
CUSTOMER REF.:			
ASSEMBLY DRG:			

HARWIN

www.harwin.com
technical@harwin.com

THIS DRAWING AND ANY INFORMATION OR DESCRIPTIVE MATTER SET OUT HEREON ARE CONFIDENTIAL AND COPYRIGHT PROPERTY OF THE HARWIN GROUP AND MUST NOT BE DISCLOSED, LOANED, COPIED OR USED FOR MANUFACTURING, TENDERING OR FOR ANY OTHER PURPOSE WITHOUT THEIR WRITTEN PERMISSION.

TOLERANCES

~~X = ±1mm
X.X = ±0.50mm
X.XX = ±0.10mm
X.XXX = ±0.01mm
ANGLES = ±5°
UNLESS STATED~~

MATERIAL:

SEE ABOVE

FINISH:

SEE ABOVE

S/AREA:

mm²

TITLE:

2.00mm PITCH DIL
VERTICAL SOCKET ASSEMBLY

DRAWING NUMBER:

M22-714XX42

SHT
2
OF 2

Mouser Electronics

Authorized Distributor

Click to View Pricing, Inventory, Delivery & Lifecycle Information:

[Harwin:](#)

[M22-7142242](#) [M22-7142042](#) [M22-7142442](#) [M22-7141742](#) [M22-7141342](#) [M22-7141142](#) [M22-7141942](#) [M22-7141542](#) [M22-7140542](#) [M22-7140942](#) [M22-7140742](#) [M22-7140342](#) [M22-7141442](#) [M22-7141042](#) [M22-7140642](#) [M22-7141842](#) [M22-7141642](#) [M22-7140442](#) [M22-7140842](#) [M22-7141242](#) [M22-7142142](#) [M22-7142542](#) [M22-7142342](#)