

P/N 1202BA	
BASE PART	1202-04
SET SCREW	I0357
CAP INLAY	I0786(SL)

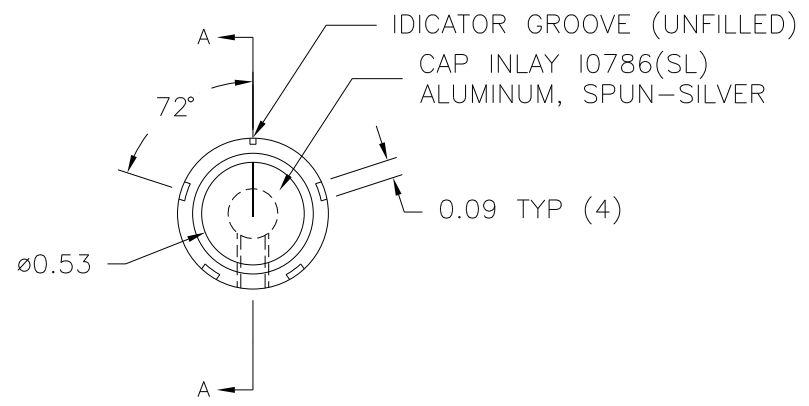

USE #28 DRILL (∅0.140), #8-32 TAP,  
#8-32 X 1/4 LG. CUP POINTED,  
SLOTTED TYPE, SET SCREW, I0357

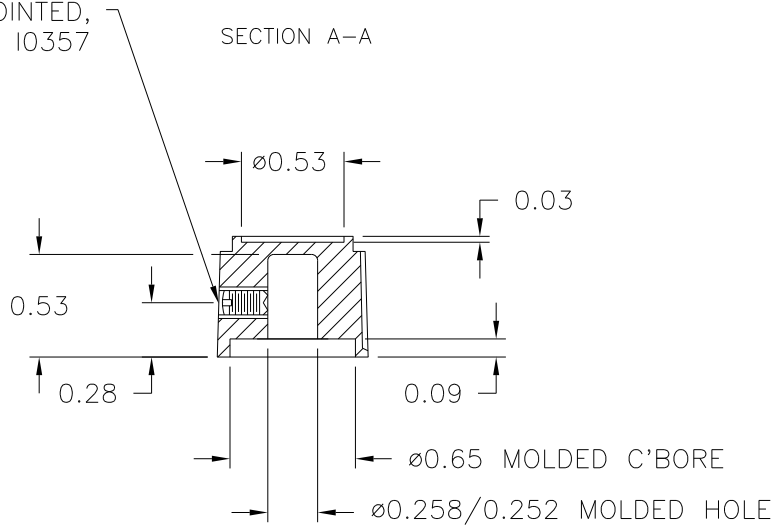
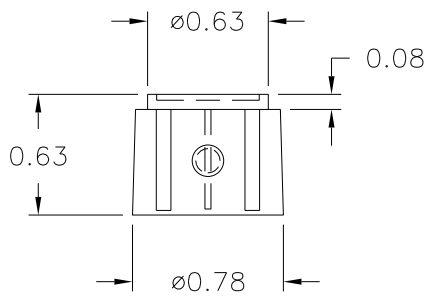

NOTE: ALL MOLDED PART(S) MUST BE CHECKED WITH PIN GAUGE.  
0.258/0.252 PIN MUST ACCEPT MOLDED HOLE  
MATERIAL: G.P. PHENOLIC (B11)  
COLOR: BLACK

TOLERANCES: UNLESS OTHERWISE SPECIFIED	DO NOT SCALE DRAWING				
DECIMALS: X.XXX ± .005 X.XX ± .015	MM: X.XX ± 0.15MM X.X ± 0.4MM	-	UPDATE/HAD TOOLBOX	ST	3/28/2000
FRACTIONS ± 1/64	ANG. ± 1°	CHANGES			

PART NAME: KNOB      SCALE: 1:1      DATE: 1/29/97      DR. BY HD

THIS DRAWING IS THE PROPERTY OF DAVIES MOLDING COMPANY, IS SUBMITTED SOLELY AS A DESIGN OR ENGINEERING PROJECT.  
 WE ACCEPT NO RESPONSIBILITY WHATSOEVER FOR THE PRACTICAL APPLICATION OF THE PIECES MADE TO THIS DESIGN.

DAVIES MOLDING COMPANY  
 CAROL STREAM, ILLINOIS 60188

P/N 1202BA

BASE PART	1202-04
SET SCREW	I0357
CAP INLAY	I0786(SL)

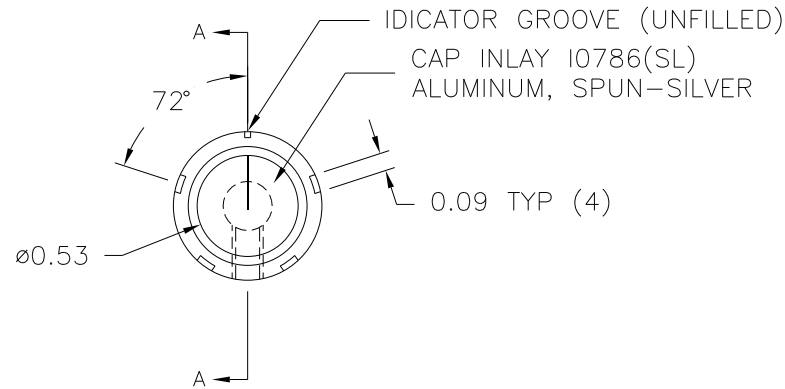

USE #28 DRILL (ø0.140), #8-32 TAP,  
 #8-32 X 1/4 LG. CUP POINTED,  
 SLOTTED TYPE, SET SCREW, I0357

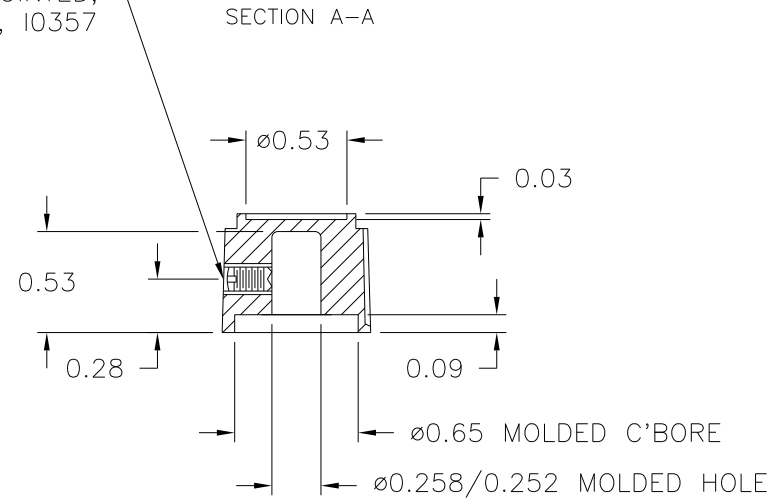
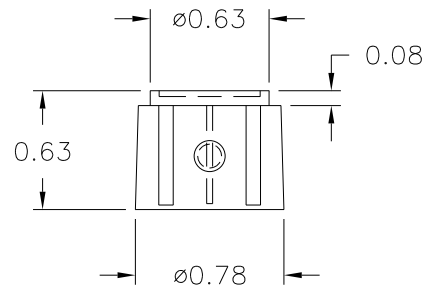

NOTE: ALL MOLDED PART(S) MUST BE CHECKED  
 WITH PIN GAUGE.  
 0.258/0.252 PIN MUST ACCEPT MOLDED HOLE  
 MATERIAL: G.P. PHENOLIC (B11)  
 COLOR: BLACK

TOLERANCES: UNLESS OTHERWISE SPECIFIED	DO NOT SCALE DRAWING			
DECIMALS: X.XXX ± .005 X.XX ± .015	MM: X.XX ± 0.15MM X.X ± 0.4MM	-	UPDATE/HAD TOOLBOX	ST 3/28/2000
FRACTIONS ± 1/64	ANG. ± 1°	CHANGES		

# Mouser Electronics

Authorized Distributor

Click to View Pricing, Inventory, Delivery & Lifecycle Information:

[Davies Molding:](#)

[1202BA](#)