



The MRC Series is a bench top re-circulating chiller that offers dependable, compact performance by controlling the temperature of a coolant in a liquid circuit. The coolant is re-circulated using a pump with high MTBF. Heat from coolant is absorbed by a heat exchanger and dissipated thru high density heat sinks equipped with brand name fans. The thermoelectric modules are custom designed to achieve long life operation. The unit is regulated with an easy to use digital temperature controller and is housed inside an aesthetic sheet metal casing. Custom configurations are available, however, MOQ applies.

Americas: +1.919.597.7300
Europe: +46.31.420530
Asia: +86.755.2714.1166
ets.sales@lairdtech.com
www.lairdtech.com

FEATURES

- Compact design
- Precise temperature control
- Reliable solid state operation
- Low noise
- RoHS compliant

APPLICATIONS

- Medical imaging systems
- Medical lasers
- Photonics laser systems
- Industrial instrumentation
- Laboratory testing

SPECIFICATIONS

Cooling capacity ¹	290 Watts
Input voltage	115 to 230 VAC
Operating environment temperature range ²	4.4°C to 45° C (40°F to 113°F)
Control temperature range using distilled H ₂ O as coolant, °C (°F) ³	2°C to 40°C (35°F to 104°F)
Control temperature range using 70% distilled H ₂ O and 30% glycol as coolant ²	-12°C to 40°C (10.4°F to 104°F)
Controller accuracy	±0.16°C
Current, 115VAC (230VAC)	8.5 (4.3) Amps
Input power	507 Watts
Frequency	50/60 Hz
Dimensions, (h x w x d)	39.1 x 20.3 x 33.8 cm (15.4 x 8.0 x 13.3) in
Weight	13.6 kgs (30 lbs)
Maximum flow rate	3.3 lpm (0.87 gpm)
Fluid capacity	450 mL (15.2 oz)
UL Rating	UL61010 – 1/IEC61010-1

1. Capacity rating is given at a temperature of 25°C (77°F) for the ambient air and exiting fluid

2. For ambient conditions outside this range, please contact Laird

3. For temperature settings below 5°C, an appropriate coolant must be used

PERFORMANCE CURVES

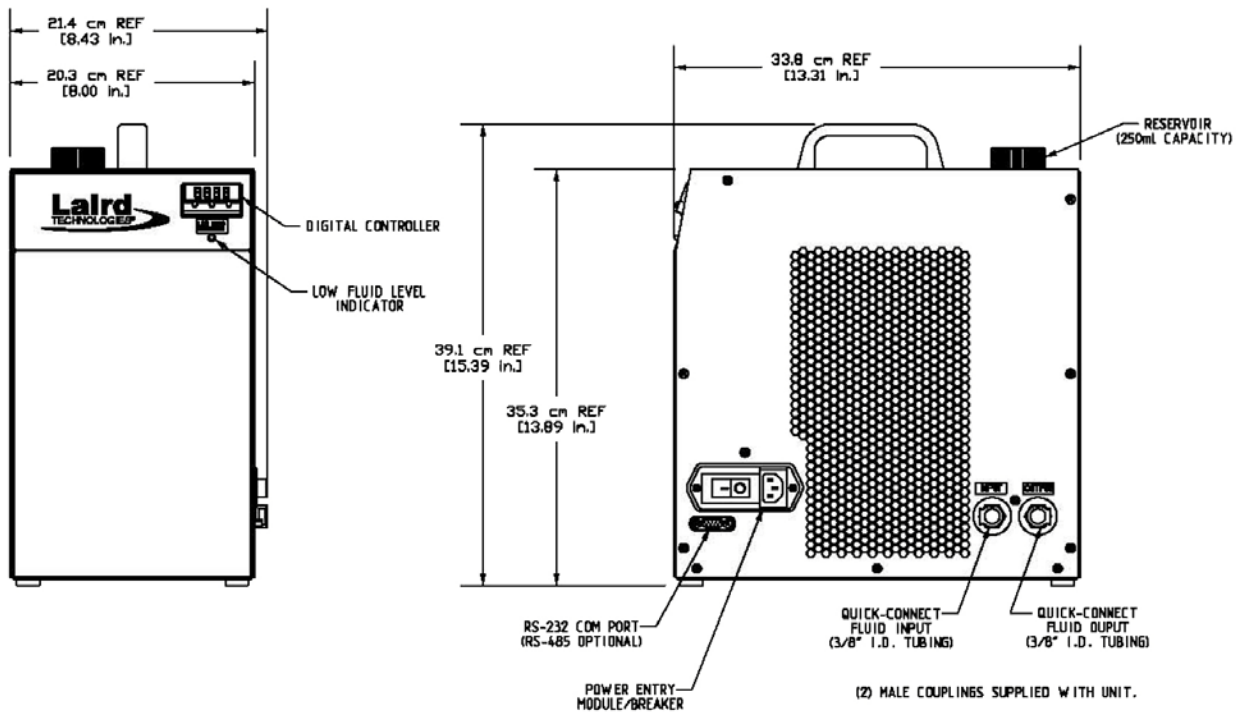
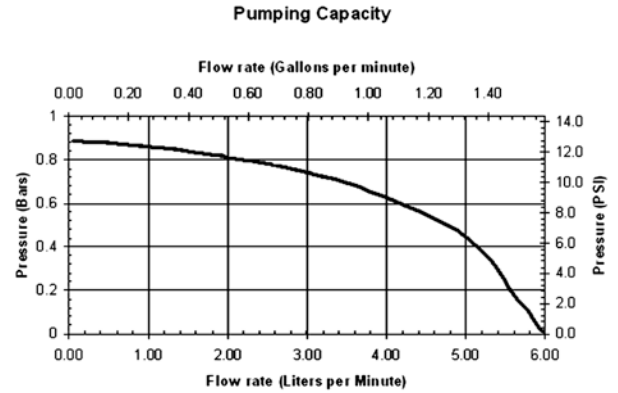
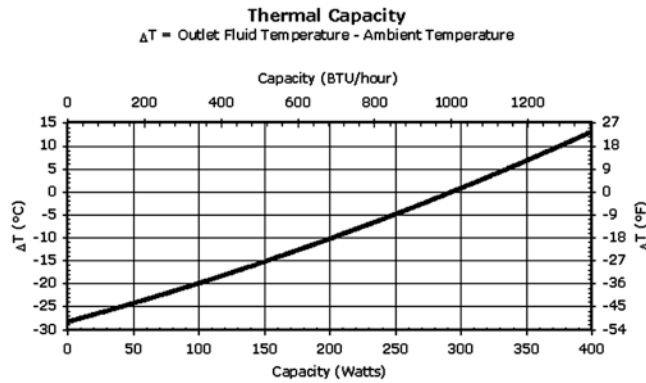

MODEL NOMENCLATURE

Model Nomenclature

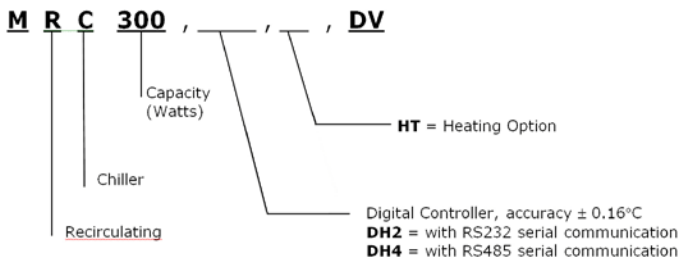

NOTES

1. Use distilled water as coolant for control temperatures above 5°C
2. To prevent freezing, use coolant with 70% distilled water and 30% glycol mix for control temperatures at or below 5°C
3. Unit comes with a 115 VAC North American cord and a 230 VAC European cord

LAIRD-ETS-MRC300-DH2-DV-DATA-SHEET-100616

Any information furnished by Laird Technologies, Inc. and its agents is believed to be accurate and reliable. All specifications are subject to change without notice. Responsibility for the use and application of Laird Technologies materials rests with the end user. Laird Technologies makes no warranties as to the fitness, merchantability, suitability or non-infringement of any Laird Technologies materials or products for any specific or general uses. Laird Technologies shall not be liable for incidental or consequential damages of any kind. All Laird Technologies products are sold pursuant to the Laird Technologies' Terms and Conditions of sale in effect from time to time, a copy of which will be furnished upon request. © Copyright 2016 Laird Technologies, Inc. All Rights Reserved. Laird, Laird Technologies, the Laird Technologies Logo, and other marks are trademarks or registered trademarks of Laird Technologies, Inc. or an affiliate company thereof. Other product or service names may be the property of third parties. Nothing herein provides a license under any Laird Technologies or any third party intellectual property rights.