



## Miniature Threaded Coupling Connector

Space saving with scoop proof connector designed for any harsh application where both size and EMI shielding are critical.

**A compact solution** ■ Diameter up to 45% smaller than D38999 size 9. Integrated backshell: up to 40% shorter.

**A high density solution** ■ With #26 contacts (according 39029). 6 layouts (size 3, 5 and 7 with #22 & #26).

**Excellent features** ■ Designed for D38999 requirements. IP67 sealing when mated. EMI ring and ratcheting system.

**RoHS and Cadmium free** ■ Available in zinc nickel (RoHS) plating, as well as nickel and olive drab cadmium.

Not QPL listed.

## Miniature sizes

- **A compact solution**
  - The smallest connector available on the market (shell size 3)
  - Miniaturization of MIL-DTL-38999 Series III
  - Threaded coupling (between 1/2 and 3/4 turn to mate) with ratcheting system (size 5 & 7)
  - Integrated backshell:
    - . Easy to wire and handle
    - . Compatible with heat shrink boot and braid retention band
    - . Compliant with overmolding
  - Triple-start thread
- **A versatile solution**
  - 3 shell sizes (3, 5, 7), 4 shell types
  - 2 materials, 4 platings
  - Crimp & PC tails contacts
  - Removable contacts #22D & #26
  - 6 keyings
- **Harsh environment-resistant solution**
  - Scoop Proof
  - Cavity to cavity sealed with interfacial seal and grommet
  - EMI ring (for size 5 & 7)
  - Fluid resistant



## Technical features

### Mechanical

- **Shell:**
  - Aluminum alloy
  - Passivated stainless steel (for size 5 & 7)
- **Shell plating:**
  - Aluminum:
    - . Zinc nickel (RoHS)
    - . Nickel (RoHS)
    - . Olive drab cadmium
  - Passivated stainless steel (RoHS)
- **Insulator:** Thermoplastic
- **Contact body:** Copper alloy
- **Contacts plating:** Gold over nickel plated
- **Shell endurance:**
  - Aluminum:
    - 500 mating/unmating cycles
  - Passivated stainless steel:
    - 1000 mating/unmating cycles
- **Vibration:**
  - 44 grms @125°C, 2 axes during 8 hours
- **Shock:**
  - 300g, 3 ms

### Electrical

- **Wire size**

Layouts	Wire (AWG)
03-05; 05-06; 07-09	24-30
03-35; 05-35; 07-35	22-28
- **Test voltage (at sea level):**
  - Size 22D: 1000 Vrms
  - Size 26: 400 Vrms
- **Contact resistance:**
  - Size 22D: <14.6 mΩ
  - Size 26: <16 mΩ
- **Contact rating:**
  - Size 22D: 5A
  - Size 26: 3A
- **Contact retention:**
  - Size 22D: 45N
  - Size 26: 30N
- **Shell to shell continuity (typical value)**

Shell size	Aluminum version	Stainless steel version
3	X	
5	10 mΩ	60 mΩ
7		
- **EMI:**
  - Aluminum: -70dB @ 1GHz
  - Passivated stainless steel: -55 dB @ 1Ghz

### Environmental

- **Temperature range:**
  - 55°C to +175°C
- **Water immersion:**
  - IP 67 on mated connector
  - 1 meter for 30 min minimum
  - > IP68 with appropriate cable termination
- **Salt spray:**
  - Zinc nickel: 500 hours
  - Nickel: 48 hours
  - Olive drab cadmium: 500 hours
  - Passivated stainless steel: 250 hours

### Resistance to fluids

- **According to MIL-DTL-38999 standard**
  - Gasoline: JP5 (OTAN F44)
  - Mineral hydraulic fluid: MIL-H-5606 (OTAN H515)
  - Synthetic hydraulic fluid: Skydrol 500 B4
- **Compatible with de-icing fluids containing potassium acetate**

## Shell types

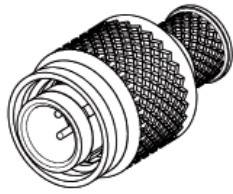

Plug

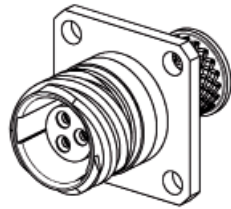

Square flange receptacle  
(PC tail version available)

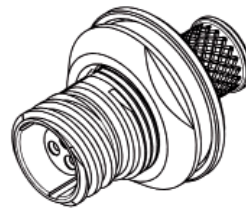

Jam nut receptacle  
(PC tail version available)

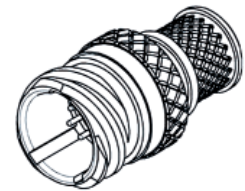

In line receptacle

For other configuration, please consult us.

## Contact layouts

03

05

35

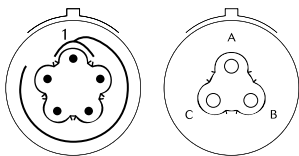

5#26

3#22D

05

06

35

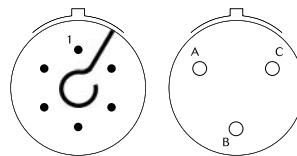

6#26

3#22D

07

09

35

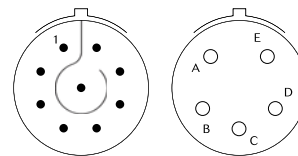

9#26

5#22D

**Size 3: Marking on shell.**

Rear view of receptacle for male and female insulator.  
Opposite marking between plug and receptacle.

**Sizes 5 and 7: Marking on insulator.**  
Rear view of male insulator for plug and receptacle.  
Opposite marking between male and female insulator.

## Ordering information

Basic Series	8DA	0	03	W	05	P	N
<b>Shell type:</b> 0: Square flange receptacle 1: In line receptacle 5: Plug with EMI ring (Size 5 & size 7) 6: Plug without EMI ring (Size 3 only) 7: Jam nut receptacle 90: Square flange receptacle with PCB contacts 97: Jam nut receptacle with PCB contacts							
<b>Contact type:</b> None: Standard crimp contacts C: Short PC tail L: Long PC tail (consult us)							
<b>Shell size:</b> 03, 05, 07							
<b>Plating :</b> Z: Black zinc nickel F: Nickel W: Olive drab cadmium K: Passivated stainless steel (only for sizes 05 & 07 with standard crimp contacts)							
<b>Contact layouts:</b> See above							
<b>Contact type:</b> P: Pin (Shell size 3 scoop proof only when pin contacts mounted in Type 6) S: Socket (Shell size 3 scoop proof only when socket contacts mounted in Types 0, 1 or 7) - not available for PCB version							
<b>Orientation:</b> N, A, B, C, D, E (see page 7)							

## Connector weights

Aluminum version - in gram  $\pm 10\%$

Shell size & layout	Plug		Square flange receptacle		Jam nut receptacle	
	Without contacts	With crimp contacts	Without contacts	With crimp contacts	Without contacts	With crimp contacts
3-05	2.4	2.5	1.9	2.1	3	3.1
5-06	6	6.2	5.4	5.8	6	6.4
7-09	6.5	6.8	6	6.5	7	7.5

## Dimensions

### Plug - Shell type 5 & 6

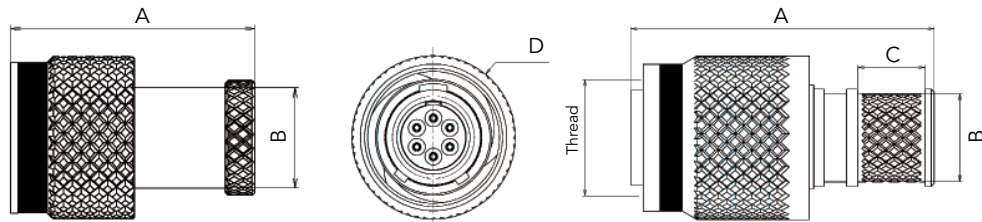

Shell size 3

Shell size 5 & 7

Shell size	Thread	A Max	ØB Max	C Max	ØD Max
3	3-05	-	17	7	-
	3-35	-	17.5	7	-
5	5/11"-1P	28	8	6.1	15
7	1/2"-1P	28	9.5	6.1	16

### In line receptacle - Shell type 1

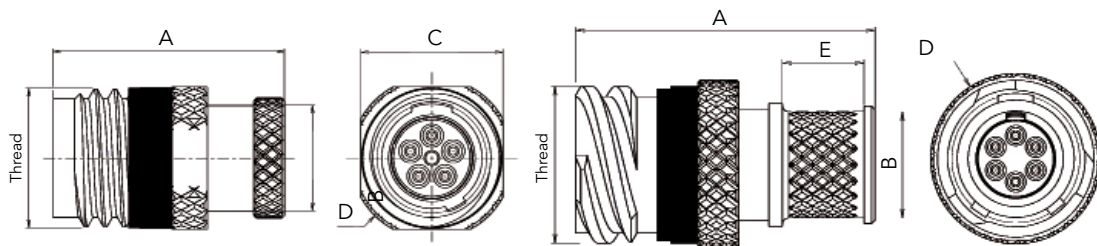

Shell size 3

Shell size 5 & 7

Shell size	Thread	A Max	B Max	C Max	ØD Max	E Max
3	M9	15.5	7	9.3	11	-
5	5/11"-1P	23	8	-	13	6.1
7	1/2"-1P	25	9.5	-	13.5	6.1

Note: All dimensions are in millimeters (mm)

**Square flange receptacle - Shell type 0**

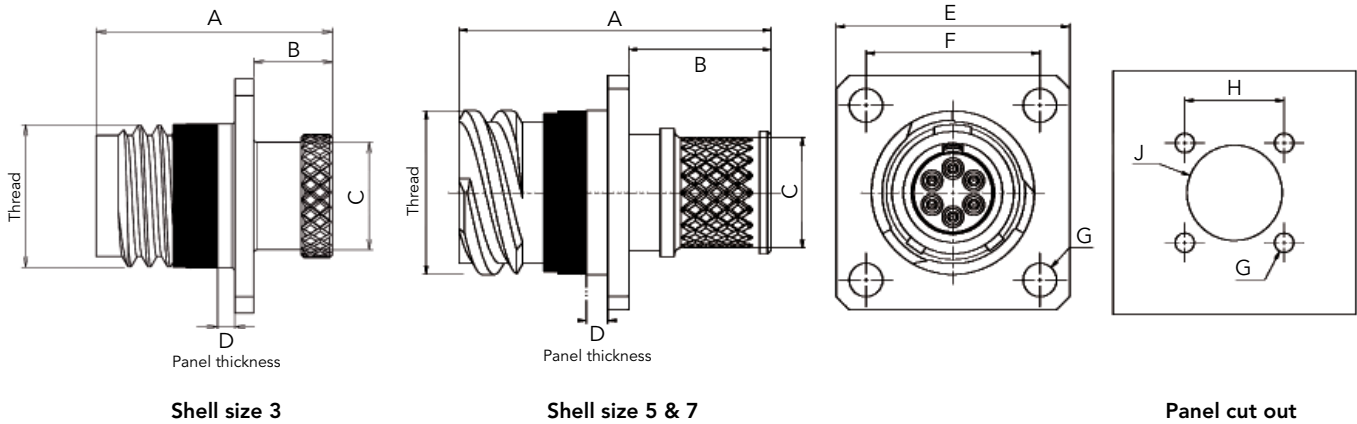

Shell size	Thread	A Max	B Max	ØC Max	D Max	E Max	F Max	ØG Max	H Max	ØJ Max	
3	3-05	M9	15	5	6.8	2.5	15	10.5	2.35 <sup>+0.08</sup>	10.5	9.5
	3-35	M9	18	8	6.8	2.5	15	10.5	2.35 <sup>+0.08</sup>	10.5	9.5
5	5/11"-1P	23	10.5	8	2.5	16.6	12.27	2.35 <sup>+0.08</sup>	12.27	11.75	
7	1/2"-1P	25	13	10	2.5	18	13.84	2.35 <sup>+0.08</sup>	13.8	12.95	

**Square flange receptacle with PC tail contacts - Shell type 90**

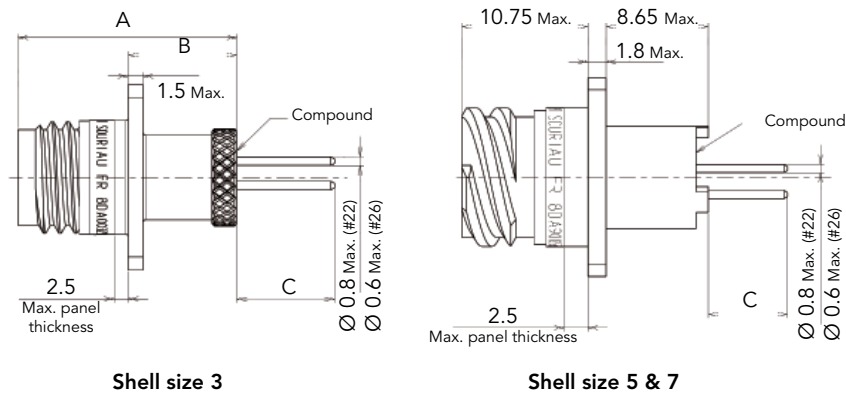

Layout	A Max.	B Max.	C Min.	C Max.
03-05	15	6.5	8.47	9.47
03-35	18	9	7.39	8.12
05-06	-	-	5.89	7
05-35	-	-	5.87	6.9
07-09	-	-	6.04	7
07-35	-	-	5.82	6.9

Shell design vary according to shell size.  
For L contact (long PC tail) please consult us.

Note: All dimensions are in millimeters (mm)

### Jam nut receptacle - Shell type 7

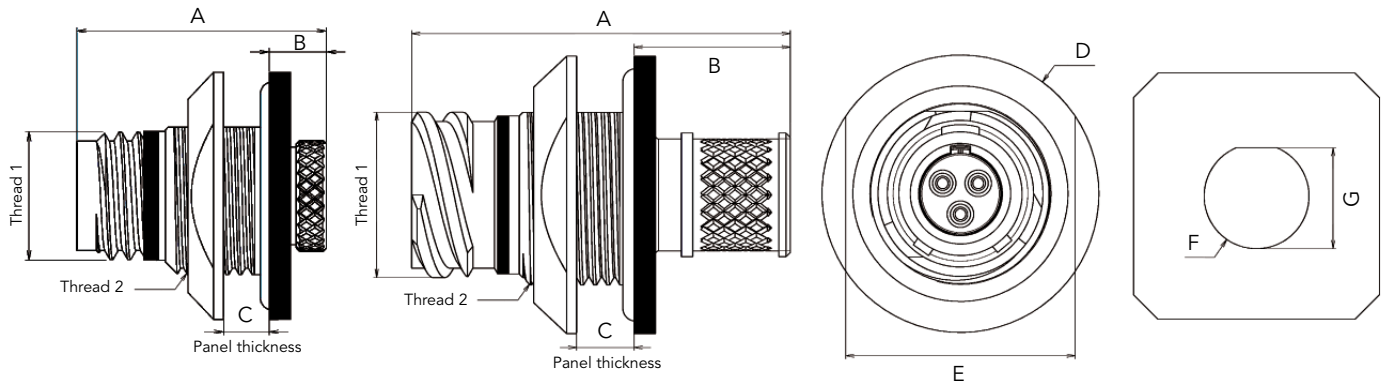

Shell size 3

Shell size 5 & 7

Panel cut out

Shell size	Thread 1	Thread 2	A Max	B Max	C Max	ØD Max	E Max	ØF Max	G Max	
3	3-05	M9	7/16"28 UNEF 2A	18	4.5	3.2	18	14	11.3	10.6
	3-35	M9	7/16"28 UNEF 2A	20	6.5	3.2	18	14	11.3	10.6
5	5/11"-1P	1/2"28 UNEF 2A	27	11	3.2	19.5	16	12.8	12.3	
7	1/2"-1P	9/16"24 UNEF 2A	27	11.5	3.2	21	17	14.5	13.8	

### Jam nut receptacle with PC tail contacts - Shell type 97

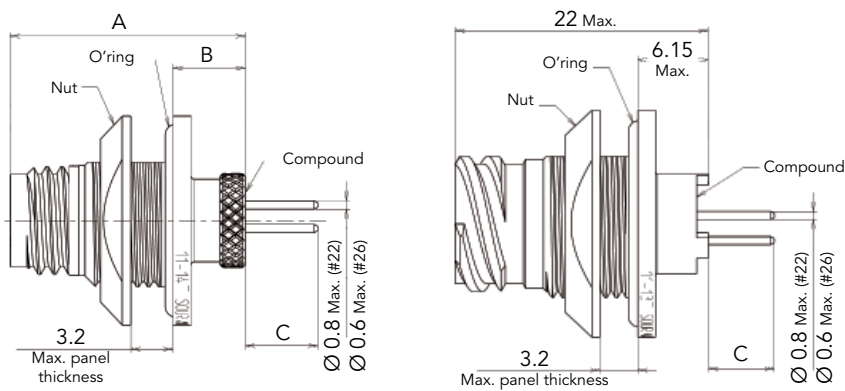

Shell size 3

Shell size 5 & 7

Layout	A Max.	B Max.	C Min.	C Max.
03-05	18.5	4.2	5.87	6.97
03-35	20.5	6.2	5.19	6.02
05-06	-	-	4.86	5.95
05-35	-	-	4.82	5.85
07-09	-	-	4.99	5.95
07-35	-	-	4.77	5.85

Shell design vary according to shell size.  
For L contact (long PC tail) please consult us.

## Orientations

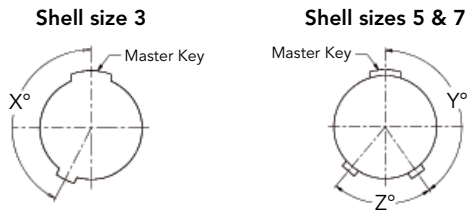

Shell size	Angles	N	A	B	C	D	E
3	X°	153	51	102	204	255	306
5 & 7	Y°	145	130	110	155	90	90
	Z°	75	120	120	115	115	180

Viewed from front face of plug

## Aluminum caps

Basic Series	8DAC	32	Z	03	N
<b>Cap type:</b>					
32: Cap for plug					
33: Cap for receptacle					
<b>Plating:</b>					
Z: Black zinc nickel					
F: Nickel					
W: Olive drab cadmium					
<b>Shell size: 03, 05, 07</b>					
<b>Style:</b>					
N: Ring					
R: Eyelet					

## Gaskets

Shell size	Part number
3	8DA0G03
5	8DA0G05
7	8DA0G07

## Dimensions

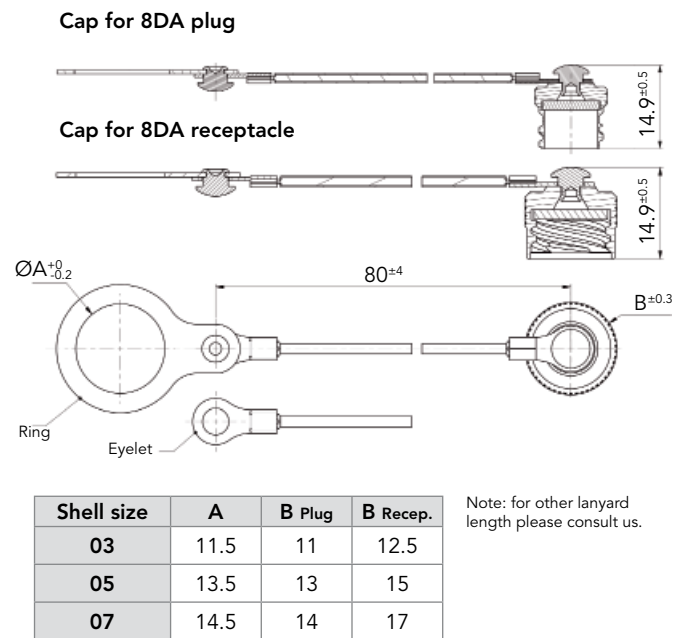

Note: All dimensions are in millimeters (mm)

For further information contact us at [contactmilaero@souriau.com](mailto:contactmilaero@souriau.com) or visit our web site [www.souriau.com](http://www.souriau.com)

# Mouser Electronics

Authorized Distributor

Click to View Pricing, Inventory, Delivery & Lifecycle Information:

Souriau:

[8DA507Z35SN](#) [8DA707Z35PN](#) [8DA007Z35PN](#) [8DA707W09PN](#) [8DA505W35PN](#) [8DA705W35SN](#) [8DA007Z09SN](#)  
[8DA703Z35SN](#)