

SECTION C-C

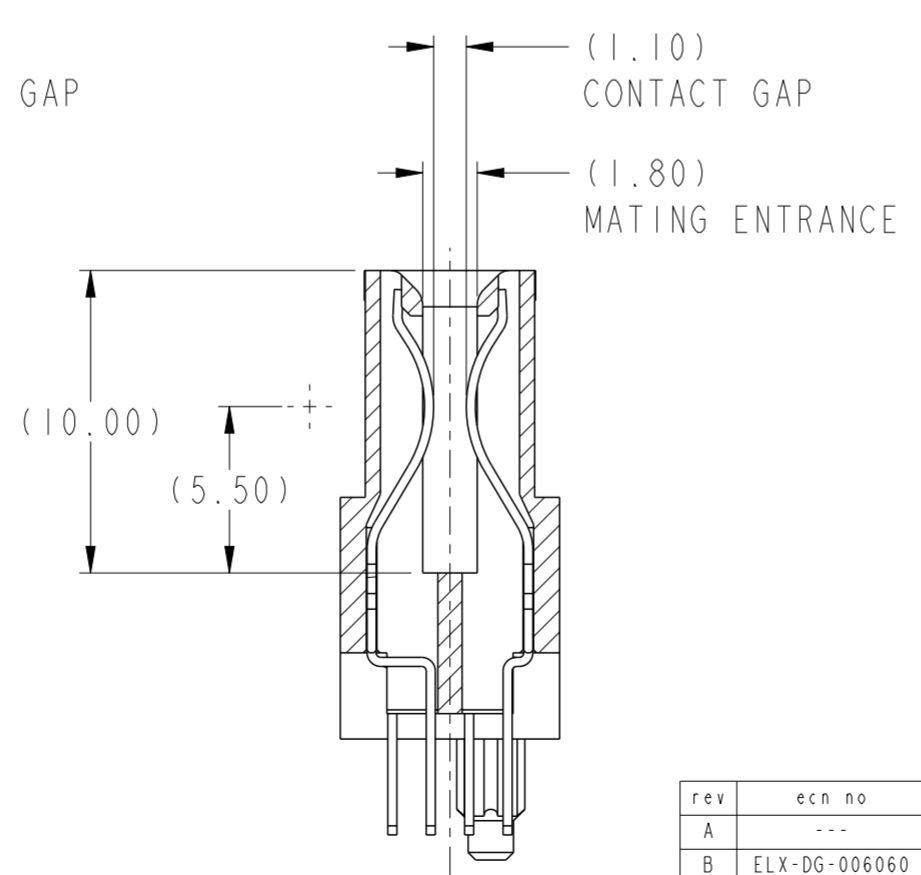

SECTION D-D

rev	ecn no	dr	date
A	---	HZ	2011-07-03
B	ELX-DG-006060	WL	2011-09-19

spec ref	-
tolerance std	ASME Y14.5
surface	linear ✓
	angular

dr	Mary Glass	2010/08/10
eng	Wei-Long Zhang	2011/09/19
chr	Jon Qin	2011/09/19
appr	Fei-Ming Zheng	2011/09/19

projection	MM	size	A2	scale	4:1
product family	HPCE	ecn no	ELX-DG-006060-1	rel level	Released
title	VERT RECT (32P-24S) HIGH POWER CARD EDGE	dwg no	10115772	rev	B
www.fci.com	cat. no.	Product - Customer Drw	sheet 1 of 4		

Copyright FCI. FCI

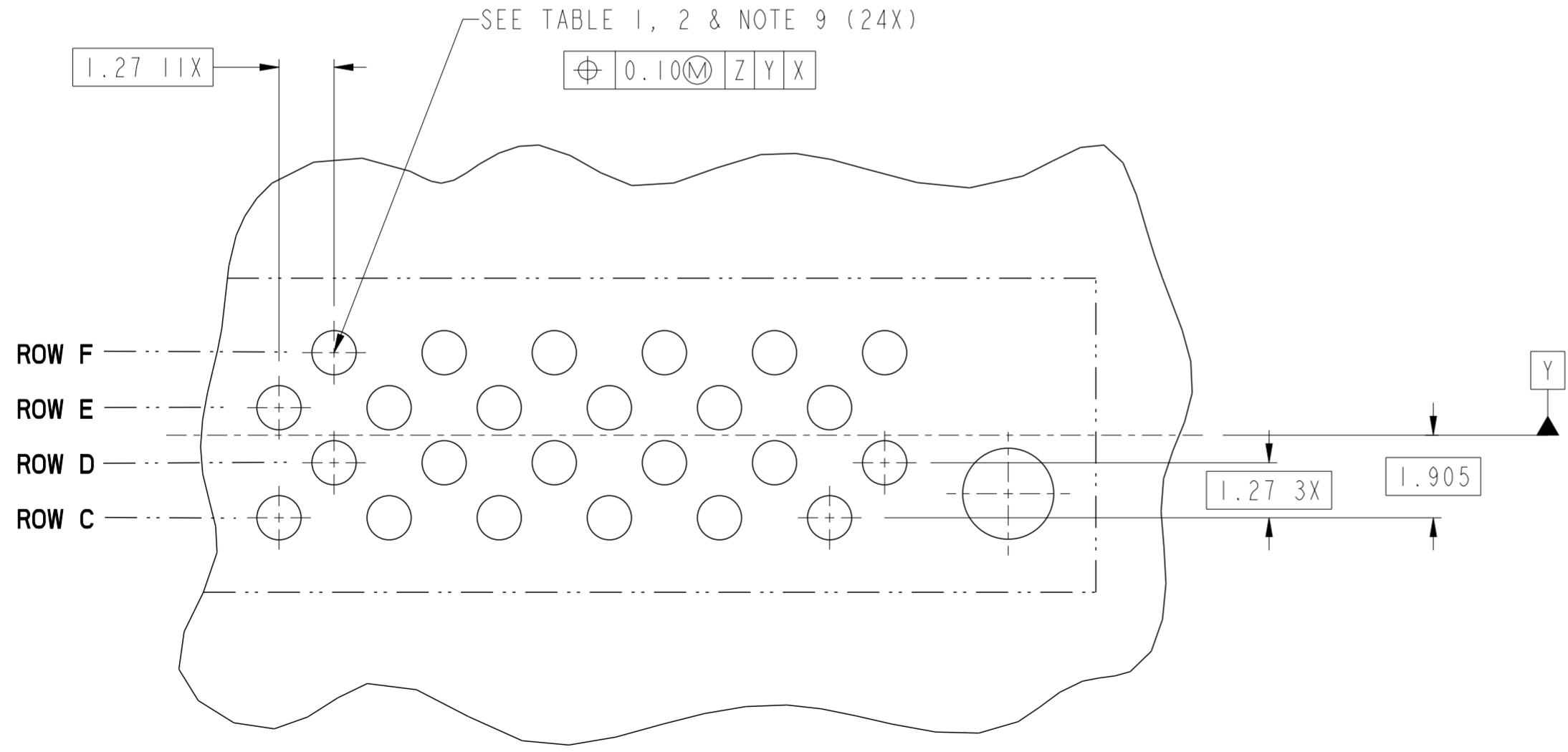
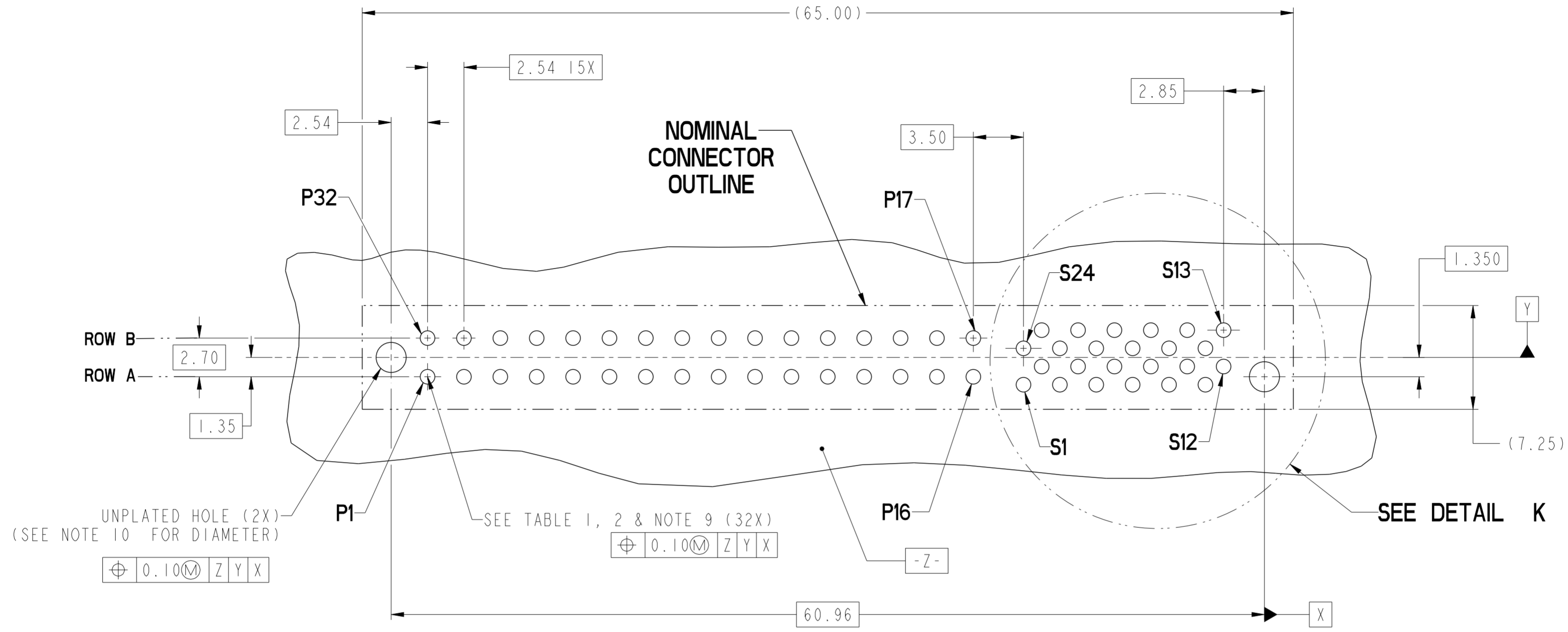

DETAIL K
SCALE 8:1

**RECOMMENDED PCB LAYOUT
VIEWED FROM CONNECTOR SIDE**

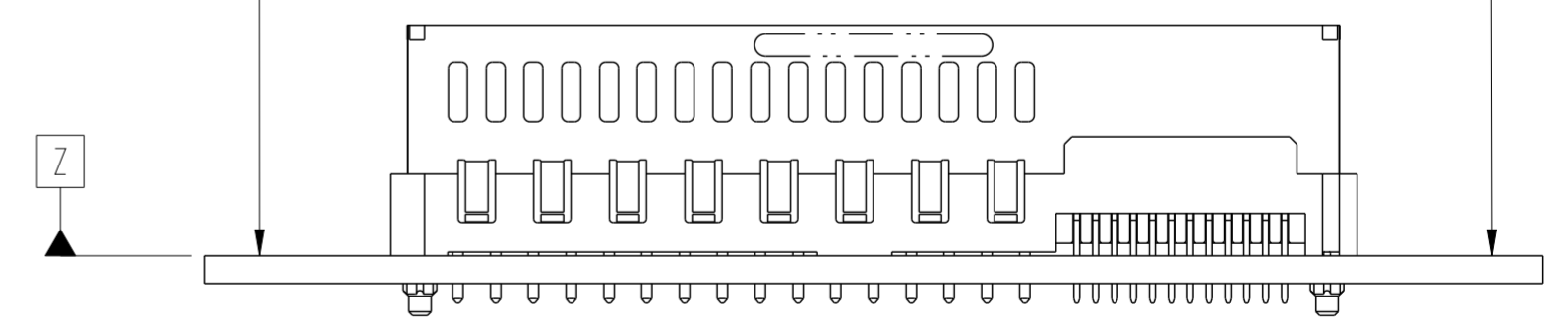

dr	Mary Glass	2010/08/10	projection	MM	size	A2	scale	4:1
eng	Wei-Long Zhang	2011/09/19			ecn no	ELX-DG-006069-1		
chr	Jon Qin	2011/09/19			rel level	Released		
appr	Pei-Ming Zheng	2011/09/19	product family	HPCE				
		title VERT RECT (32P-24S) HIGH POWER CARD EDGE		dwg no 10115772		rev B		
www.fci.com		cat. no.		-		Product - Customer Draw		sheet 2 of 4

Copyright FCI.

CONTACT TYPE	TOP LAYER DESCRIPTION	TABLE 1 (HPCE / SOLDER TAILS) PLATED THROUGH-HOLE REQUIREMENTS				
		DRILLED HOLE DIAMETER	COPPER THICKNESS	TIN-LEAD THICKNESS	TIN THICKNESS	FINISHED HOLE DIAMETER
POWER & SIGNAL	TIN-LEAD	1.10-1.16 (1.15 DRILL)	0.025 - 0.050	0.005 - 0.015	--	0.94 - 1.10
	IMMERSION TIN	1.10-1.16 (1.15 DRILL)	0.025 - 0.050	--	0.9 - 1.5um	0.94 - 1.10
	COPPER (SEE NOTE 8)	1.10-1.16 (1.15 DRILL)	0.025 - 0.050	--	--	0.94 - 1.10

CONTACT TYPE	TOP LAYER DESCRIPTION	TABLE 2 (HPCE / PRESS-FIT TAILS) PLATED THROUGH-HOLE REQUIREMENTS				
		DRILLED HOLE DIAMETER	COPPER THICKNESS	TIN-LEAD THICKNESS	TIN THICKNESS	FINISHED HOLE DIAMETER
POWER & SIGNAL	TIN-LEAD	0.81-0.86 (0.85 DRILL)	0.025 - 0.050	0.005 - 0.015	--	0.65 - 0.80
	IMMERSION TIN	0.81-0.86 (0.85 DRILL)	0.025 - 0.050	--	0.9 - 1.5um	0.70 - 0.80
	COPPER (SEE NOTE 8)	0.81-0.86 (0.85 DRILL)	0.025 - 0.050	--	--	0.70 - 0.80

RECOMMENDED MATING BOARD FOOTPRINT

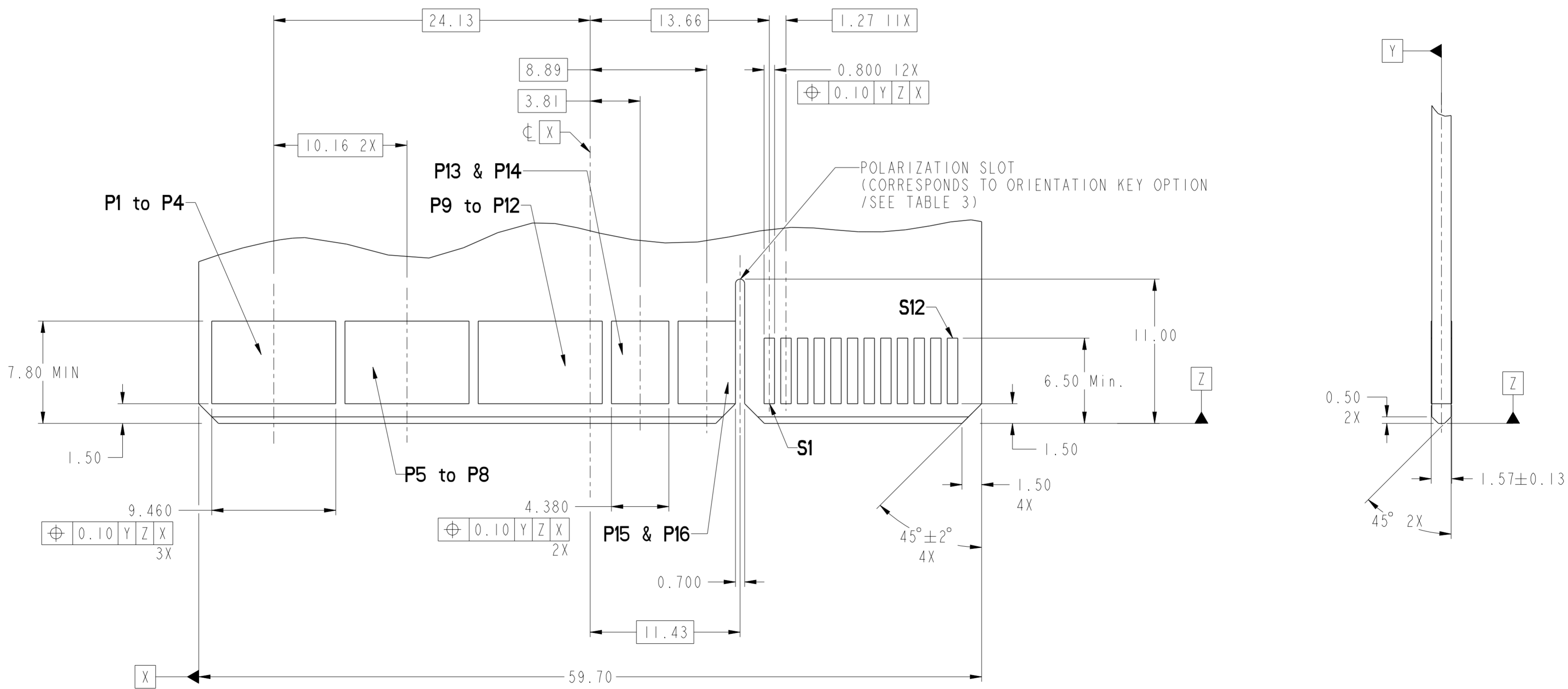

dr	Mary Glass	2010/08/10	projection	MM	size	A2	scale	4:1	
eng	Wei-Long Zhang	2011/09/19			ecn no	ELX-DG-006069-1	rel level	Released	
chr	Jon Qin	2011/09/19							
appr	Pei-Ming Zheng	2011/09/19	product family	HPCE					
			title	VERT RECT (32P-24S)		dwg no	10115772		
www.fci.com			cat. no.	-		Product - Customer Drw	sheet 3 of 4	rev	B

Copyright FCI. FCI

HPCE PART NUMBER (TABLE 3)

PART NUMBER	TAIL TYPE	ORIENTATION KEY	DIM "A" TYPICAL TAIL LENGTH	DIM "B" RECOMMENDED BOARD THICKNESS
10115772-001LF	SOLDER	YES	3.17 ±0.25	1.59 - 2.38
10115772-002LF	SOLDER	NO		
10115772-003	PRESS-FIT	YES	3.17 ±0.25	1.57 MIN
10115772-003LF	PRESS-FIT	YES		
10115772-004	PRESS-FIT	NO		
10115772-004LF	PRESS-FIT	NO		

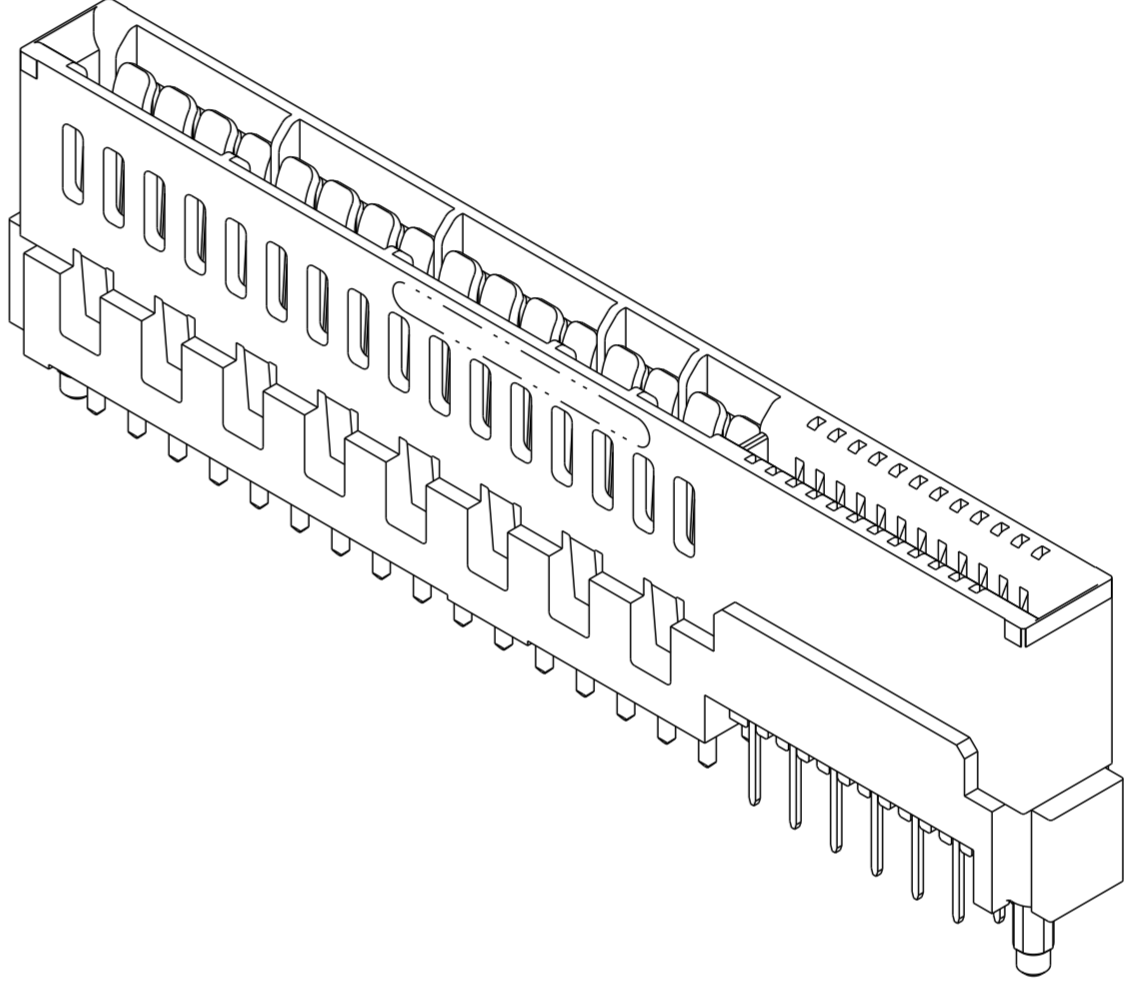

NOTES:

1. CONNECTOR MATERIALS:
 HOUSING: HIGH TEMPERATURE THERMAL PLASTIC, BLACK
 UL 94V-0 COMPLIANT
 CONTACTS: HIGH PERFORMANCE COPPER ALLOY.
2. CONTACT FINISH REF. GS-12-604 SECTION 5.2.
3. PRODUCT SPECIFICATION: GS-12-604.
4. APPLICATION SPECIFICATION: GS-20-128.
5. PRODUCT MARKING (PRODUCT NUMBER & DATE CODE) ON HOUSING IN AREA SHOWN.
6. PACKAGING MEETS FCI SPECIFICATION GS-14-937.
7. HOUSING COMPONENT WILL WITHSTAND EXPOSURE TO 260°C PEAK TEMPERATURE FOR 60 SECONDS IN A CONVECTION, INFRA-RED, OR VAPOR PHASE REFLOW OVEN.
8. COPPER PLATING THICKNESS IN CENTER OF VIA-HOLE CAN BE NO MORE THAN 0.003 LESS THAN OTHER AREAS.
9. ALL HOLE SIZES ARE FINISHED HOLE SIZES.
10. MOUNTING HOLES ARE UNPLATED
 Ø 2.40 +/- 0.1 FOR PRESS-FIT TAILS
 Ø 2.10 +/- 0.1 FOR SOLDER TAILS

dr	Mary Glass	2010/08/10	projection	MM	size	A2	scale	4:1	
eng	Wei-Long Zhang	2011/09/19			ecn no	ELX-DG-006060-1			
chr	Jon Qin	2011/09/19			product family	HPCE	rel level	Released	
appr	Pai-Ming Zheng	2011/09/19			title	VERT RECT (32P-24S) HIGH POWER CARD EDGE		rev	B
www.fci.com			cat. no.	-	Product - Customer Drw	sheet 4 of 4			

Copyright FCI. FCI

Mouser Electronics

Authorized Distributor

Click to View Pricing, Inventory, Delivery & Lifecycle Information:

[FCI / Amphenol:](#)

[10115772-003LF](#) [10115772-002LF](#) [10115772-001LF](#) [10115772-004LF](#)