

108 dB, 192 kHz 6-In, 8-Out CODEC

FEATURES

- ◆ Six 24-bit A/D, Eight 24-bit D/A Converters
- ◆ ADC Dynamic Range
 - 105 dB Differential
 - 102 dB Single-Ended
- ◆ DAC Dynamic Range
 - 108 dB Differential
 - 105 dB Single-Ended
- ◆ ADC/DAC THD+N
 - -98 dB Differential
 - -95 dB Single-Ended
- ◆ Compatible with Industry-Standard Time Division Multiplexed (TDM) Serial Interface
- ◆ System Sampling Rates up to 192 kHz
- ◆ Programmable ADC High-Pass Filter for DC Offset Calibration
- ◆ Logarithmic Digital Volume Control
- ◆ I²C™ & SPI™ Host Control Port
- ◆ Supports Logic Levels Between 5 V and 1.8 V
- ◆ Popguard® Technology

GENERAL DESCRIPTION

The CS42448 CODEC provides six multi-bit analog-to-digital and eight multi-bit digital-to-analog delta-sigma converters. The CODEC is capable of operation with either differential or single-ended inputs and outputs, in a 64-pin LQFP package.

Six fully differential, or single-ended, inputs are available on stereo ADC1, ADC2, and ADC3. When operating in Single-Ended Mode, an internal MUX before ADC3 allows selection from up to four single-ended inputs. Digital volume control is provided for each ADC channel, with selectable overflow detection.

All eight DAC channels provide digital volume control and can operate with differential or single-ended outputs.

An auxiliary serial input is available for an additional two channels of PCM data.

The CS42448 is available in a 64-pin LQFP package in Commercial (-10°C to +70°C) and Automotive (-40°C to +105°C) grades. The CDB42448 Customer Demonstration Board is also available for device evaluation and implementation suggestions. Please refer to [“Ordering Information” on page 65](#) for complete ordering information.

The CS42448 is ideal for audio systems requiring wide dynamic range, negligible distortion and low noise, such as A/V receivers, DVD receivers, and automotive audio systems.

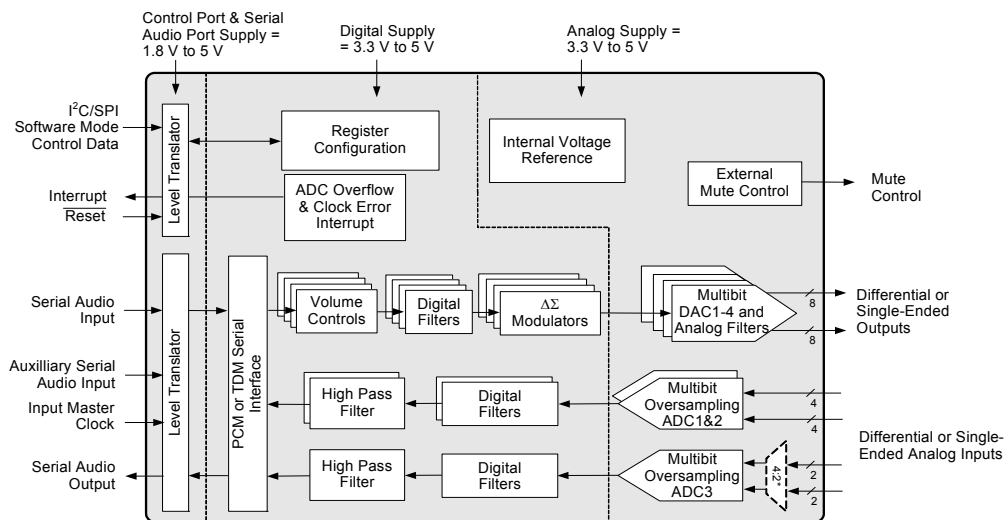

*Optional MUX allows selection from up to 4 single-ended inputs.

TABLE OF CONTENTS

1. PIN DESCRIPTIONS	6
1.1 Digital I/O Pin Characteristics	8
2. TYPICAL CONNECTION DIAGRAM	9
3. CHARACTERISTICS AND SPECIFICATIONS	10
RECOMMENDED OPERATING CONDITIONS	10
ABSOLUTE MAXIMUM RATINGS	10
ANALOG INPUT CHARACTERISTICS (COMMERCIAL)	11
ANALOG INPUT CHARACTERISTICS (AUTOMOTIVE)	12
ADC DIGITAL FILTER CHARACTERISTICS	13
ANALOG OUTPUT CHARACTERISTICS (COMMERCIAL)	14
ANALOG OUTPUT CHARACTERISTICS (AUTOMOTIVE)	15
COMBINED DAC INTERPOLATION & ON-CHIP ANALOG FILTER RESPONSE	17
SWITCHING SPECIFICATIONS - ADC/DAC PORT	18
SWITCHING CHARACTERISTICS - AUX PORT	20
SWITCHING SPECIFICATIONS - CONTROL PORT - I ² C MODE	21
SWITCHING SPECIFICATIONS - CONTROL PORT - SPI FORMAT	22
DC ELECTRICAL CHARACTERISTICS	23
DIGITAL INTERFACE SPECIFICATIONS & CHARACTERISTICS	24
4. APPLICATIONS	25
4.1 Overview	25
4.2 Analog Inputs	25
4.2.1 Line-Level Inputs	25
4.2.2 ADC3 Analog Input	26
4.2.3 High-Pass Filter and DC Offset Calibration	27
4.3 Analog Outputs	27
4.3.1 Initialization	27
4.3.2 Output Transient Control	29
4.3.3 Popguard	29
4.3.3.1 Power-Up	29
4.3.3.2 Power-Down	29
4.3.4 Mute Control	29
4.3.5 Line-Level Outputs and Filtering	30
4.3.6 Digital Volume Control	30
4.3.7 De-Emphasis Filter	30
4.4 System Clocking	31
4.5 CODEC Digital Interface Formats	32
4.5.1 I ² S	33
4.5.2 Left-Justified	33
4.5.3 Right-Justified	33
4.5.4 OLM #1	33
4.5.5 OLM #2	34
4.5.6 TDM	34
4.5.7 I/O Channel Allocation	35
4.6 AUX Port Digital Interface Formats	35
4.6.1 I ² S	35
4.6.2 Left-Justified	36
4.7 Control Port Description and Timing	36
4.7.1 SPI Mode	36
4.7.2 I ² C Mode	37
4.8 Interrupts	38
4.9 Recommended Power-Up Sequence	39
4.10 Reset and Power-Up	39

4.11 Power Supply, Grounding, and PCB Layout	39
5. REGISTER QUICK REFERENCE	40
6. REGISTER DESCRIPTION	42
6.1 Memory Address Pointer (MAP)	42
6.1.1 Increment (INCR)	42
6.1.2 Memory Address Pointer (MAP[6:0])	42
6.2 Chip I.D. and Revision Register (Address 01h) (Read Only)	42
6.2.1 Chip I.D. (CHIP_ID[3:0])	42
6.2.2 Chip Revision (REV_ID[3:0])	42
6.3 Power Control (Address 02h)	43
6.3.1 Power Down ADC Pairs (PDN_ADCX)	43
6.3.2 Power Down DAC Pairs (PDN_DACX)	43
6.3.3 Power Down (PDN)	43
6.4 Functional Mode (Address 03h)	44
6.4.1 DAC Functional Mode (DAC_FM[1:0])	44
6.4.2 ADC Functional Mode (ADC_FM[1:0])	44
6.4.3 MCLK Frequency (MFREQ[2:0])	44
6.5 Interface Formats (Address 04h)	45
6.5.1 Freeze Controls (FREEZE)	45
6.5.2 Auxiliary Digital Interface Format (AUX_DIF)	45
6.5.3 DAC Digital Interface Format (DAC_DIF[2:0])	45
6.5.4 ADC Digital Interface Format (ADC_DIF[2:0])	46
6.6 ADC Control & DAC De-Emphasis (Address 05h)	46
6.6.1 ADC1-2 High-Pass Filter Freeze (ADC1-2_HPF FREEZE)	46
6.6.2 ADC3 High Pass Filter Freeze (ADC3_HPF FREEZE)	47
6.6.3 DAC De-Emphasis Control (DAC_DEM)	47
6.6.4 ADC1 Single-Ended Mode (ADC1 SINGLE)	47
6.6.5 ADC2 Single-Ended Mode (ADC2 SINGLE)	47
6.6.6 ADC3 Single-Ended Mode (ADC3 SINGLE)	48
6.6.7 Analog Input Ch. 5 Multiplexer (AIN5_MUX)	48
6.6.8 Analog Input Ch. 6 Multiplexer (AIN6_MUX)	48
6.7 Transition Control (Address 06h)	48
6.7.1 Single Volume Control (DAC_SNGVOL, ADC_SNGVOL)	48
6.7.2 Soft Ramp and Zero Cross Control (ADC_SZC[1:0], DAC_SZC[1:0])	49
6.7.3 Auto-Mute (AMUTE)	49
6.7.4 Mute ADC Serial Port (MUTE_ADC_SP)	50
6.8 DAC Channel Mute (Address 07h)	50
6.8.1 Independent Channel Mute (AOUTX_MUTE)	50
6.9 AOUTX Volume Control (Addresses 08h- 0Fh)	50
6.9.1 Volume Control (AOUTX_VOL[7:0])	50
6.10 DAC Channel Invert (Address 10h)	51
6.10.1 Invert Signal Polarity (INV_AOUTX)	51
6.11 AINX Volume Control (Address 11h-16h)	51
6.11.1 AINX Volume Control (AINX_VOL[7:0])	51
6.12 ADC Channel Invert (Address 17h)	51
6.12.1 Invert Signal Polarity (INV_AINX)	51
6.13 Status Control (Address 18h)	52
6.13.1 Interrupt Pin Control (INT[1:0])	52
6.14 Status (Address 19h) (Read Only)	52
6.14.1 DAC CLOCK ERROR (DAC_CLK ERROR)	52
6.14.2 ADC CLOCK ERROR (ADC_CLK ERROR)	52
6.14.3 ADC Overflow (ADCX_OVFL)	52
6.15 Status Mask (Address 1Ah)	53
6.16 MUTEC Pin Control (Address 1Bh)	53

6.17 MUTE C Polarity Select (MCPOLARITY)	53
6.18 MUTE CONTROL ACTIVE (MUTE C ACTIVE)	53
7. EXTERNAL FILTERS	54
7.1 ADC Input Filter	54
7.1.1 Passive Input Filter	55
7.1.2 Passive Input Filter w/Attenuation	55
7.2 DAC Output Filter	57
8. ADC FILTER PLOTS	58
9. DAC FILTER PLOTS	60
10. PARAMETER DEFINITIONS	62
11. REFERENCES	63
12. PACKAGE INFORMATION	64
12.1 Thermal Characteristics	64
13. ORDERING INFORMATION	65
14. REVISION HISTORY	65

LIST OF FIGURES

Figure 1. Typical Connection Diagram	9
Figure 2. Output Test Circuit for Maximum Load	16
Figure 3. Maximum Loading	16
Figure 4. Serial Audio Interface Slave Mode Timing	18
Figure 5. TDM Serial Audio Interface Timing	18
Figure 6. Serial Audio Interface Master Mode Timing	19
Figure 7. Serial Audio Interface Timing	20
Figure 8. Control Port Timing - I ² C Format	21
Figure 9. Control Port Timing - SPI Format	22
Figure 10. Full-Scale Input	26
Figure 11. ADC3 Input Topology	26
Figure 12. Audio Output Initialization Flow Chart	28
Figure 13. Full-Scale Output	30
Figure 14. De-Emphasis Curve	31
Figure 15. I ² S Format	33
Figure 16. Left Justified Format	33
Figure 17. Right Justified Format	33
Figure 18. One-Line Mode #1 Format	33
Figure 19. One Line Mode #2 Format	34
Figure 20. TDM Format	34
Figure 21. AUX I ² S Format	35
Figure 22. AUX Left-Justified Format	36
Figure 23. Control Port Timing in SPI Mode	37
Figure 24. Control Port Timing, I ² C Write	37
Figure 25. Control Port Timing, I ² C Read	38
Figure 26. Single to Differential Active Input Filter	54
Figure 27. Single-Ended Active Input Filter	54
Figure 28. Passive Input Filter	55
Figure 29. Passive Input Filter w/Attenuation	56
Figure 30. Active Analog Output Filter	57
Figure 31. Passive Analog Output Filter	57
Figure 32. SSM Stopband Rejection	58
Figure 33. SSM Transition Band	58
Figure 34. SSM Transition Band (Detail)	58
Figure 35. SSM Passband Ripple	58
Figure 36. DSM Stopband Rejection	58

Figure 37.DSM Transition Band	58
Figure 38.DSM Transition Band (Detail)	59
Figure 39.DSM Passband Ripple	59
Figure 40.QSM Stopband Rejection	59
Figure 41.QSM Transition Band	59
Figure 42.QSM Transition Band (Detail)	59
Figure 43.QSM Passband Ripple	59
Figure 44.SSM Stopband Rejection	60
Figure 45.SSM Transition Band	60
Figure 46.SSM Transition Band (detail)	60
Figure 47.SSM Passband Ripple	60
Figure 48.DSM Stopband Rejection	60
Figure 49.DSM Transition Band	60
Figure 50.DSM Transition Band (detail)	61
Figure 51.DSM Passband Ripple	61
Figure 52.QSM Stopband Rejection	61
Figure 53.QSM Transition Band	61
Figure 54.QSM Transition Band (detail)	61
Figure 55.QSM Passband Ripple	61

LIST OF TABLES

Table 1. I/O Power Rails	8
Table 2. Single-Speed Mode Common Frequencies	31
Table 3. Double-Speed Mode Common Frequencies	31
Table 4. Quad-Speed Mode Common Frequencies	31
Table 5. I ² S, LJ, RJ Clock Ratios	32
Table 6. OLM #1 Clock Ratios	32
Table 7. OLM #2 Clock Ratios	32
Table 8. TDM Clock Ratios	32
Table 9. Serial Audio Interface Channel Allocations	35
Table 10. MCLK Frequency Settings for I ² S, Left and Right Justified Interface Formats	44
Table 12. DAC Digital Interface Formats	45
Table 11. MCLK Frequency Settings for TDM & OLM Interface Formats	45
Table 13. ADC Digital Interface Formats	46
Table 14. Example AOUT Volume Settings	50
Table 15. Example AIN Volume Settings	51

1. PIN DESCRIPTIONS

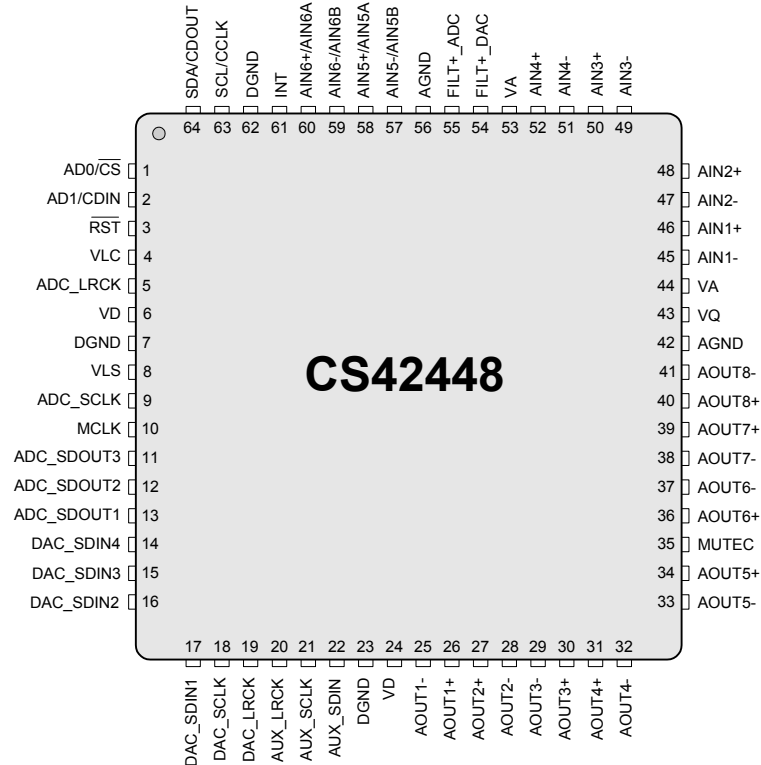

Pin Name	#	Pin Description
AD0/CS	1	Address Bit [0]/ Chip Select (Input) - Chip address bit in I ² C Mode. Control signal used to select the chip in SPI Mode.
AD1/CDIN	2	Address Bit [1]/ SPI Data Input (Input) - Chip address bit in I ² C Mode. Input for SPI data.
RST	3	Reset (Input) - The device enters a low power mode and all internal registers are reset to their default settings when low.
VLC	4	Control Port Power (Input) - Determines the required signal level for the control port. See "Digital I/O Pin Characteristics" on page 8.
ADC_LRCK	5	ADC Left/Right Clock (Input/Output) - Determines which channel, Left or Right, is currently active on the ADC serial audio data line. Signals the start of a new TDM frame in the TDM digital interface format.
VD	6, 24	Digital Power (Input) - Positive terminal of the power supply for the digital section.
DGND	7, 23, 62	Digital Ground (Input) - Ground terminal of the power supply for the digital section.
VLS	8	Serial Port Interface Power (Input) - Determines the required signal level for the serial interfaces. See "Digital I/O Pin Characteristics" on page 8.
ADC_SCLK	9	ADC Serial Clock (Input/Output) - Serial clock for the ADC serial audio interface. Input frequency must be 256xFs in the TDM digital interface format.
MCLK	10	Master Clock (Input) - Clock source for the delta-sigma modulators and digital filters.
ADC_SDOOUT1 ADC_SDOOUT2 ADC_SDOOUT3	13 12 11	Serial Audio Data Output (Output) - Outputs for two's complement serial audio data.

DAC_SDIN1	17	DAC Serial Audio Data Input (Input) - Input for two's complement serial audio data.
DAC_SDIN2	16	
DAC_SDIN3	15	
DAC_SDIN4	14	
DAC_SCLK	18	DAC Serial Clock (Input/Output) - Serial clock for the DAC serial audio interface. Input frequency must be 256x F_s in the TDM digital interface format.
DAC_LRCK	19	DAC Left/Right Clock (Input/Output) - Determines which channel, Left or Right, is currently active on the DAC serial audio data line. Signals the start of a new TDM frame in the TDM digital interface format.
AUX_LRCK	20	Auxiliary Left/Right Clock (Output) - Determines which channel, Left or Right, is currently active on the Auxiliary serial audio data line. Derived from the ADC serial port and equals F_s .
AUX_SCLK	21	Auxiliary Serial Clock (Output) - Serial clock for the Auxiliary serial audio interface.
AUX_SDIN	22	Auxiliary Serial Input (Input) - Provides an additional serial input for two's complement serial audio data. Used only in the TDM digital interface format.
AOUT1 +,-	26,25	Differential Analog Output (Output) - The full-scale analog output level is specified in the Analog Characteristics table. Each leg of the differential outputs may also be used single-ended.
AOUT2 +,-	27,28	
AOUT3 +,-	30,29	
AOUT4 +,-	31,32	
AOUT5 +,-	34,33	
AOUT6 +,-	36,37	
AOUT7 +,-	39,38	
AOUT8 +,-	40,41	
AGND	42,56	Analog Ground (Input) - Ground reference for the analog section.
VQ	43	Quiescent Voltage (Output) - Filter connection for internal quiescent reference voltage.
VA	44,53	Analog Power (Input) - Positive power supply for the analog section. See “Digital I/O Pin Characteristics” on page 8 .
AIN1 +,-	46,45	Differential Analog Input (Input) - Signals are presented differentially or single-ended to the delta-sigma modulators. The full-scale input level is specified in the Analog Characteristics specification table. See below for a description of AIN5-AIN6 in Single-Ended Mode.
AIN2 +,-	48,47	
AIN3 +,-	50,49	
AIN4 +,-	52,51	
AIN5 +,-	58,57	
AIN6 +,-	60,59	
AIN5 A,B AIN6 A,B	58,57 60,59	Single-Ended Analog Input (Input) - When stereo ADC3 is in Single-Ended Mode, an internal analog mux allows selection between 2 channels for both analog inputs AIN5 and AIN6 (see Section 4.2.2 on page 26 for details). The unused leg of each input is internally connected to common mode. The full-scale input level is specified in the Analog Characteristics table.
MUTE_C	35	Mute Control (Output) - Used as a control for external mute circuits to prevent the clicks and pops that can occur in any single supply system.
FILT+_DAC	54	Positive Voltage Reference (Output) - Positive reference voltage for the internal sampling circuits of the DAC.
FILT+_ADC	55	Positive Voltage Reference (Output) - Positive reference voltage for the internal sampling circuits of the ADC.
INT	61	Interrupt (Output) - Signals either an ADC overflow condition has occurred in one or more of the ADC inputs, or a clocking error has occurred in the DAC/ADC as specified in the Interrupt register.
SCL/CCLK	63	Serial Control Port Clock (Input) - Serial clock for the control port interface.
SDA/CDOUT	64	Serial Control Data I/O (Input/Output) - Input/Output for I ² C data. Output for SPI data.

1.1 Digital I/O Pin Characteristics

Various pins on the CS42448 are powered from separate power supply rails. The logic level for each input should adhere to the corresponding power rail and should not exceed the maximum ratings.

Power Rail	Pin Name	I/O	Driver	Receiver
VLC	$\overline{\text{RST}}$	Input	-	1.8 V - 5.0 V, CMOS
	SCL/CCLK	Input	-	1.8 V - 5.0 V, CMOS, with Hysteresis
	SDA/CDOUT	Input/ Output	1.8 V - 5.0 V, CMOS/Open Drain	1.8 V - 5.0 V, CMOS, with Hysteresis
	$\overline{\text{AD0/CS}}$	Input	-	1.8 V - 5.0 V, CMOS
	AD1/CDIN	Input	-	1.8 V - 5.0 V, CMOS
	INT	Output	1.8 V - 5.0 V, CMOS/Open Drain	-
VLS	MCLK	Input	-	1.8 V - 5.0 V, CMOS
	ADC_LRCK	Input/ Output	1.8 V - 5.0 V, CMOS	1.8 V - 5.0 V, CMOS
	ADC_SCLK	Input/ Output	1.8 V - 5.0 V, CMOS	1.8 V - 5.0 V, CMOS
	ADC_SDOOUT1-3	Output	1.8 V - 5.0 V, CMOS	-
	DAC_LRCK	Input/ Output	1.8 V - 5.0 V, CMOS	1.8 V - 5.0 V, CMOS
	DAC_SCLK	Input/ Output	1.8 V - 5.0 V, CMOS	1.8 V - 5.0 V, CMOS
	DAC_SDIN1-4	Input	-	1.8 V - 5.0 V, CMOS
	AUX_LRCK	Output	1.8 V - 5.0 V, CMOS	-
	AUX_SCLK	Output	1.8 V - 5.0 V, CMOS	-
	AUX_SDIN	Input	-	1.8 V - 5.0 V, CMOS
VA	MUTECH	Output	3.3 V - 5.0 V, CMOS	-

Table 1. I/O Power Rails

2. TYPICAL CONNECTION DIAGRAM

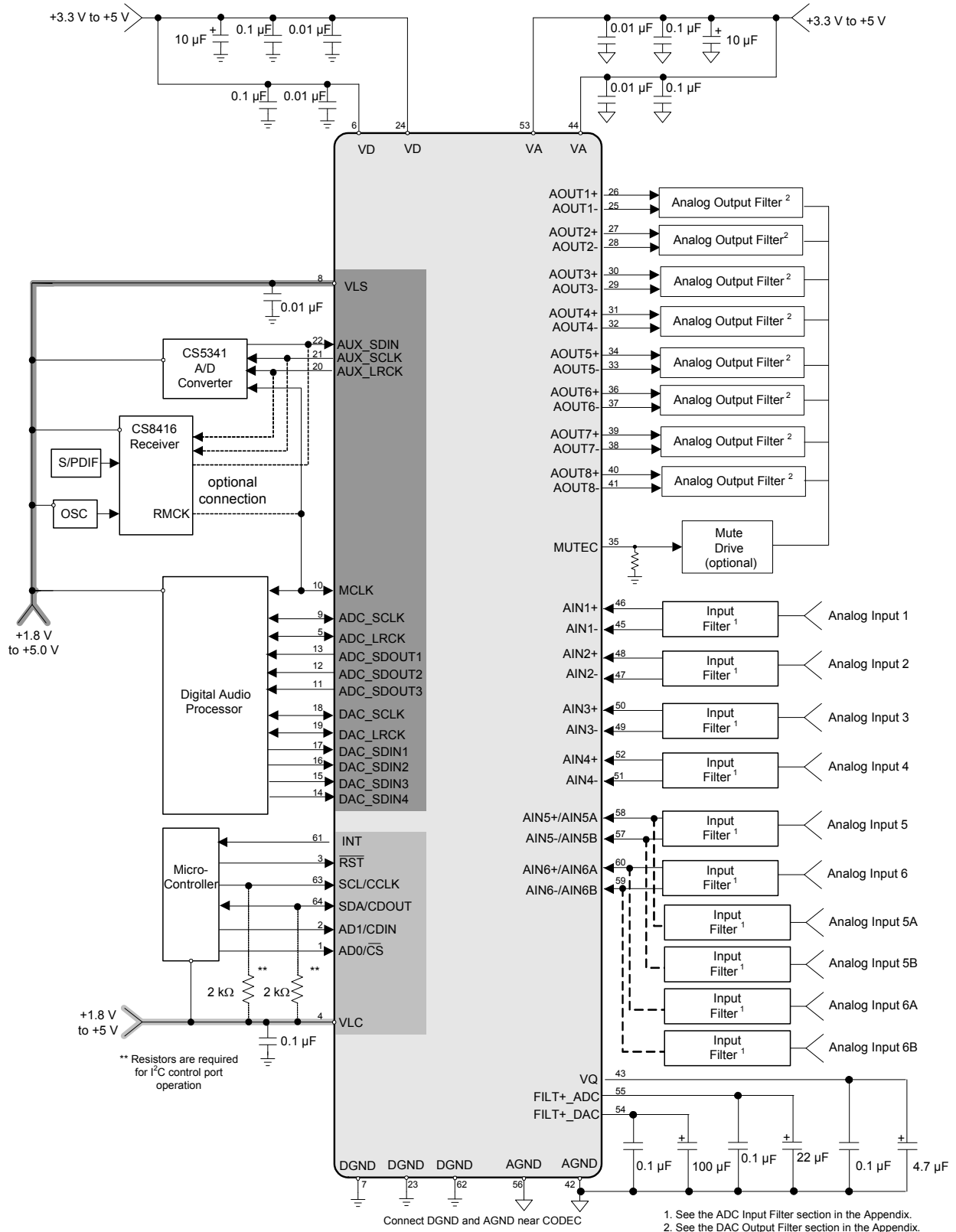

Figure 1. Typical Connection Diagram

3. CHARACTERISTICS AND SPECIFICATIONS

RECOMMENDED OPERATING CONDITIONS

(AGND = DGND = 0 V, all voltages with respect to ground.)

Parameters	Symbol	Min	Max	Units
DC Power Supply				
Analog (Note 1)	VA	3.14	5.25	V
Digital	VD	3.14	5.25	V
Serial Audio Interface (Note 2)	VLS	1.71	5.25	V
Control Port Interface	VLC	1.71	5.25	V
Ambient Temperature				
Commercial -CQZ	T _A	-10	+70	°C
Automotive -DQZ		-40	+105	°C

ABSOLUTE MAXIMUM RATINGS

(AGND = DGND = 0 V; all voltages with respect to ground.)

Parameters	Symbol	Min	Max	Units
DC Power Supply	Analog VA	-0.3	6.0	V
	Digital VD	-0.3	6.0	V
	Serial Port Interface VLS	-0.3	6.0	V
	Control Port Interface VLC	-0.3	6.0	V
Input Current (Note 3)	I _{in}	-	±10	mA
Analog Input Voltage (Note 4)	V _{IN}	AGND-0.7	VA+0.7	V
Digital Input Voltage	Serial Port Interface V _{IND-S}	-0.3	VLS+ 0.4	V
	Control Port Interface V _{IND-C}	-0.3	VLC+ 0.4	V
Ambient Operating Temperature (power applied)	T _A	-50	+125	°C
Storage Temperature	T _{stg}	-65	+150	°C

WARNING: Operation at or beyond these limits may result in permanent damage to the device. Normal operation is not guaranteed at these extremes.

Notes:

1. Typical Analog input/output performance will slightly degrade at VA = 3.3 V.
2. The ADC_SDOUT may not meet timing requirements in TDM, Double-Speed Mode.
3. Any pin except supplies. Transient currents of up to ±100 mA on the analog input pins will not cause SCR latch-up.
4. The maximum over/under voltage is limited by the input current.

ANALOG INPUT CHARACTERISTICS (COMMERCIAL)

Test Conditions (unless otherwise specified): $T_A = -10$ to $+70^\circ\text{C}$; $V_D = V_{LS} = V_{LC} = 3.3\text{ V} \pm 5\%$, $V_A = 5\text{ V} \pm 5\%$;
 Full-scale input sine wave: 1 kHz through the active input filter in [Figure 26 on page 54](#) and [Figure 27 on page 54](#);
 Measurement Bandwidth is 10 Hz to 20 kHz.

Parameter		Differential			Single-Ended			Unit
		Min	Typ	Max	Min	Typ	Max	
Fs=48 kHz, 96 kHz, 192 kHz								
Dynamic Range	A-weighted	99	105	-	96	102	-	dB
	unweighted	96	102	-	93	99	-	dB
	40 kHz bandwidth unweighted	-	99	-	-	96	-	dB
Total Harmonic Distortion + Noise (Note 5)	-1 dB	-	-98	-92	-	-95	-89	dB
	-20 dB	-	-82	-	-	-79	-	dB
	-60 dB	-	-42	-	-	-39	-	dB
	40 kHz bandwidth -1 dB	-	-90	-	-	-90	-	dB
ADC1-3 Interchannel Isolation		-	90	-	-	90	-	dB
ADC3 MUX Interchannel Isolation		-	90	-	-	90	-	dB
DC Accuracy								
Interchannel Gain Mismatch		-	0.1	-	-	0.1	-	dB
Gain Drift		-	± 100	-	-	± 100	-	ppm/ $^\circ\text{C}$
Analog Input								
Full-Scale Input Voltage		1.06*VA	1.12*VA	1.18*VA	0.53*VA	0.56*VA	0.59*VA	Vpp
Differential Input Impedance (Notes 6 & 8)		23	29	32				k Ω
Single-Ended Input Impedance (Notes 7 & 8)		-	-	-	23	29	32	k Ω
Common Mode Rejection Ratio (CMRR)		-	82	-	-	-	-	dB

ANALOG INPUT CHARACTERISTICS (AUTOMOTIVE)

Test Conditions (unless otherwise specified): $T_A = -40$ to $+85^\circ\text{C}$; $V_D = V_{LS} = V_{LC} = 3.3\text{ V} \pm 5\%$, $V_A = 5\text{ V} \pm 5\%$;
 Full-scale input sine wave: 1 kHz through the active input filter in [Figure 26 on page 54](#) and [Figure 27 on page 54](#);
 Measurement Bandwidth is 10 Hz to 20 kHz.

Parameter		Differential			Single-Ended			Unit
		Min	Typ	Max	Min	Typ	Max	
Fs=48 kHz, 96 kHz, 192 kHz								
Dynamic Range	A-weighted	97	105	-	94	102	-	dB
	unweighted	94	102	-	91	99	-	dB
	40 kHz bandwidth unweighted	-	99	-	-	96	-	dB
Total Harmonic Distortion + Noise (Note 5)	-1 dB	-	-98	-90	-	-95	-87	dB
	-20 dB	-	-82	-	-	-79	-	dB
	-60 dB	-	-42	-	-	-39	-	dB
	40 kHz bandwidth -1 dB	-	-87	-	-	-87	-	dB
ADC1-3 Interchannel Isolation		-	90	-	-	90	-	dB
ADC3 MUX Interchannel Isolation		-	85	-	-	85	-	dB
DC Accuracy								
Interchannel Gain Mismatch		-	0.1	-	-	0.1	-	dB
Gain Drift		-	± 100	-	-	± 100	-	ppm/ $^\circ\text{C}$
Analog Input								
Full-Scale Input Voltage		1.04*VA	1.12*VA	1.20*VA	0.52*VA	0.56*VA	0.60*VA	Vpp
Differential Input Impedance (Notes 6 & 8)		23	29	32				k Ω
Single-Ended Input Impedance (Notes 7 & 8)		-	-	-	23	29	32	k Ω
Common Mode Rejection Ratio (CMRR)		-	82	-	-	-	-	dB

Notes:

5. Referred to the typical full-scale voltage.
6. Measured between AINx+ and AINx-.
7. Measured between AINxx and AGND.
8. The input impedance scales inversely proportionate to the sample rate of the ADC modulator.

ADC DIGITAL FILTER CHARACTERISTICS

Parameter (Notes 9, 10)		Min	Typ	Max	Unit
Single-Speed Mode (Note 10)					
Passband (Frequency Response)	to -0.1 dB corner	0	-	0.4896	Fs
Passband Ripple		-	-	0.08	dB
Stopband		0.5688	-	-	Fs
Stopband Attenuation		70	-	-	dB
Total Group Delay		-	12/Fs	-	s
Double-Speed Mode (Note 10)					
Passband (Frequency Response)	to -0.1 dB corner	0	-	0.4896	Fs
Passband Ripple		-	-	0.16	dB
Stopband		0.5604	-	-	Fs
Stopband Attenuation		69	-	-	dB
Total Group Delay		-	9/Fs	-	s
Quad-Speed Mode (Note 10)					
Passband (Frequency Response)	to -0.1 dB corner	0	-	0.2604	Fs
Passband Ripple		-	-	0.16	dB
Stopband		0.5000	-	-	Fs
Stopband Attenuation		60	-	-	dB
Total Group Delay		-	5/Fs	-	s
High-Pass Filter Characteristics					
Frequency Response	-3.0 dB	-	1	-	Hz
	-0.13 dB		20	-	Hz
Phase Deviation	@ 20 Hz	-	10	-	Deg
Passband Ripple		-	-	0	dB
Filter Settling Time		-	10 ⁵ /Fs	0	s

Notes:

9. Filter response is guaranteed by design.
10. Response is clock-dependent and will scale with Fs. Note that the response plots (Figures 32 to 43) have been normalized to Fs and can be de-normalized by multiplying the X-axis scale by Fs.

ANALOG OUTPUT CHARACTERISTICS (COMMERCIAL)

Test Conditions (unless otherwise specified): $T_A = -10$ to $+70^\circ\text{C}$; $V_D = V_{LS} = V_{LC} = 3.3\text{ V} \pm 5\%$, $V_A = 5\text{ V} \pm 5\%$;
 Full-scale 997 Hz output sine wave (see [Note 12](#)) into passive filter in [Figure 32 on page 58](#) and active filter in [Figure 32 on page 58](#); Measurement Bandwidth is 10 Hz to 20 kHz.

Parameter	Differential			Single-Ended			Unit	
	Min	Typ	Max	Min	Typ	Max		
<i>F_s = 48 kHz, 96 kHz, 192 kHz</i>								
Dynamic Range								
18 to 24-Bit	A-weighted	102	108	-	99	105	-	dB
	unweighted	99	105	-	96	102	-	dB
16-Bit	A-weighted	-	99	-	-	96	-	dB
	unweighted	-	96	-	-	93	-	dB
Total Harmonic Distortion + Noise								
18 to 24-Bit	0 dB	-	-98	-92	-	-95	-89	dB
	-20 dB	-	-85	-	-	-82	-	dB
	-60 dB	-	-45	-	-	-42	-	dB
16-Bit	0 dB	-	-93	-	-	-90	-	dB
	-20 dB	-	-76	-	-	-73	-	dB
	-60 dB	-	-36	-	-	-33	-	dB
Interchannel Isolation	(1 kHz)	-	100	-	-	100	-	dB
<i>Analog Output</i>								
Full-Scale Output		1.235•V _A	1.300•V _A	1.365•V _A	0.618•V _A	0.650•V _A	0.683•V _A	V _{pp}
Interchannel Gain Mismatch		-	0.1	0.25	-	0.1	0.25	dB
Gain Drift		-	±100	-	-	±100	-	ppm/°C
Output Impedance		-	100	-	-	100	-	Ω
DC Current draw from an AOUT pin	(Note 11)	-	-	10	-	-	10	μA
AC-Load Resistance (R _L)	(Note 13)	3	-	-	3	-	-	kΩ
Load Capacitance (C _L)	(Note 13)	-	-	100	-	-	100	pF

ANALOG OUTPUT CHARACTERISTICS (AUTOMOTIVE)

Test Conditions (unless otherwise specified): $T_A = -40$ to $+85^\circ\text{C}$; $V_D = V_{LS} = V_{LC} = 3.3\text{ V} \pm 5\%$, $V_A = 5\text{ V} \pm 5\%$; Full-scale 997 Hz output sine wave (see [Note 12](#)) in [Figure 32 on page 58](#) and [Figure 32 on page 58](#); Measurement Bandwidth is 10 Hz to 20 kHz.

Parameter	Differential			Single-Ended			Unit	
	Min	Typ	Max	Min	Typ	Max		
<i>F_s = 48 kHz, 96 kHz, 192 kHz</i>								
Dynamic Range								
18 to 24-Bit	A-weighted	100	108	-	97	105	-	dB
	unweighted	97	105	-	94	102	-	dB
16-Bit	A-weighted	-	99	-	-	96	-	dB
	unweighted	-	96	-	-	93	-	dB
Total Harmonic Distortion + Noise								
18 to 24-Bit	0 dB	-	-98	-90	-	-95	-87	dB
	-20 dB	-	-85	-	-	-82	-	dB
	-60 dB	-	-45	-	-	-42	-	dB
16-Bit	0 dB	-	-93	-	-	-90	-	dB
	-20 dB	-	-76	-	-	-73	-	dB
	-60 dB	-	-36	-	-	-33	-	dB
Interchannel Isolation (1 kHz)		-	100	-	-	100	-	dB
<i>Analog Output</i>								
Full-Scale Output		1.210•V _A	1.300•V _A	1.392•V _A	0.605•V _A	0.650•V _A	0.696•V _A	V _{pp}
Interchannel Gain Mismatch		-	0.1	0.25	-	0.1	0.25	dB
Gain Drift		-	±100	-	-	±100	-	ppm/°C
Output Impedance		-	100	-	-	100	-	Ω
DC Current draw from an AOUT pin (Note 11)		-	-	10	-	-	10	μA
AC-Load Resistance (R _L) (Note 13)		3	-	-	3	-	-	kΩ
Load Capacitance (C _L) (Note 13)		-	-	100	-	-	100	pF

Notes:

- Guaranteed by design. The DC current draw represents the allowed current draw from the AOUT pin due to typical leakage through the electrolytic DC-blocking capacitors.
- One LSB of triangular PDF dither is added to data.
- Guaranteed by design. See [Figure 2](#). R_L and C_L reflect the recommended minimum resistance and maximum capacitance required for the internal op-amp's stability and signal integrity. In this circuit topology, C_L will effectively move the dominant pole of the two-pole amp in the output stage. Increasing this value beyond the recommended 100 pF can cause the internal op-amp to become unstable. See ["External Filters" on page 54](#) for a recommended output filter.

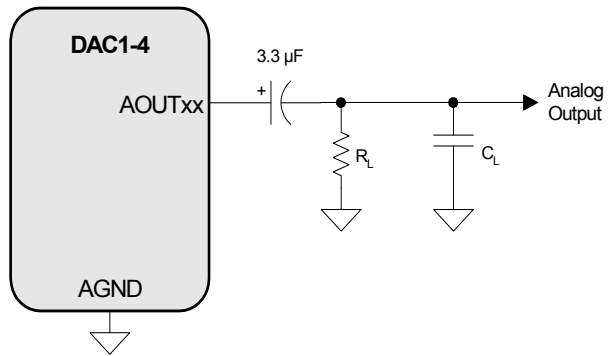

Figure 2. Output Test Circuit for Maximum Load

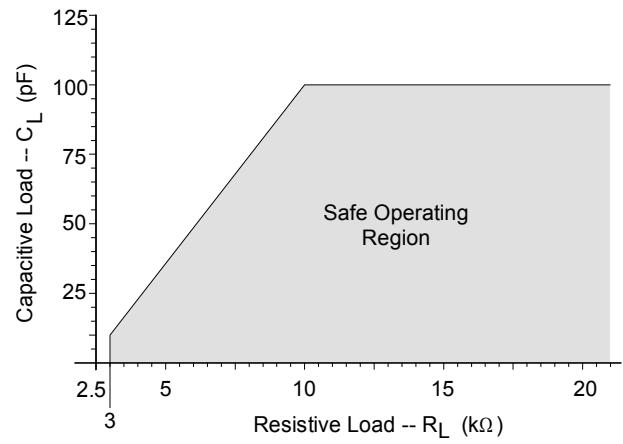

Figure 3. Maximum Loading

COMBINED DAC INTERPOLATION & ON-CHIP ANALOG FILTER RESPONSE

Parameter (Notes 9, 14)	Min	Typ	Max	Unit	
Single-Speed Mode					
Passband (Frequency Response)	to -0.05 dB corner	0	-	0.4780	Fs
	to -3 dB corner	0	-	0.4996	Fs
Frequency Response 10 Hz to 20 kHz	-0.2	-	+0.08	dB	
StopBand	0.5465	-	-	Fs	
StopBand Attenuation (Note 15)	50	-	-	dB	
Group Delay	-	10/Fs	-	s	
De-emphasis Error (Note 16)	Fs = 32 kHz	-	-	+1.5/+0	dB
	Fs = 44.1 kHz	-	-	+0.05/-0.25	dB
	Fs = 48 kHz	-	-	-0.2/-0.4	dB
Double-Speed Mode					
Passband (Frequency Response)	to -0.1 dB corner	0	-	0.4650	Fs
	to -3 dB corner	0	-	0.4982	Fs
Frequency Response 10 Hz to 20 kHz	-0.2	-	+0.7	dB	
StopBand	0.5770	-	-	Fs	
StopBand Attenuation (Note 15)	55	-	-	dB	
Group Delay	-	5/Fs	-	s	
Quad-Speed Mode					
Passband (Frequency Response)	to -0.1 dB corner	0	-	0.397	Fs
	to -3 dB corner	0	-	0.476	Fs
Frequency Response 10 Hz to 20 kHz	-0.2	-	+0.05	dB	
StopBand	0.7	-	-	Fs	
StopBand Attenuation (Note 15)	51	-	-	dB	
Group Delay	-	2.5/Fs	-	s	

Notes:

14. Response is clock-dependent and will scale with Fs. Note that the response plots (Figures 44 to 55) have been normalized to Fs and can be de-normalized by multiplying the X-axis scale by Fs.
15. Single- and Double-Speed Mode Measurement Bandwidth is from Stopband to 3 Fs.
Quad-Speed Mode Measurement Bandwidth is from Stopband to 1.34 Fs.
16. De-emphasis is only available in Single-Speed Mode.

SWITCHING SPECIFICATIONS - ADC/DAC PORT

Inputs: Logic 0 = DGND, Logic 1 = VLS, ADC_SDOUT $C_{LOAD} = 15$ pF.

Parameters (Note 21)	Symbol	Min	Max	Units	
Slave Mode					
RST pin Low Pulse Width (Note 17)		1	-	ms	
MCLK Frequency		0.512	50	MHz	
MCLK Duty Cycle (Note 18)		45	55	%	
Input Sample Rate (LRCK)	Single-Speed Mode	F_s	4	50	kHz
	Double-Speed Mode (Note 19)	F_s	50	100	kHz
	Quad-Speed Mode (Note 20)	F_s	100	200	kHz
LRCK Duty Cycle		45	55	%	
SCLK Duty Cycle		45	55	%	
SCLK High Time	t_{sckh}	8	-	ns	
SCLK Low Time	t_{sckl}	8	-	ns	
LRCK Rising Edge to SCLK Rising Edge	t_{fss} t_{lcks}	5	-	ns	
SCLK Rising Edge to LRCK Falling Edge	t_{fsh}	16	-	ns	
SCLK Falling Edge to ADC_SDOUT Output Valid	t_{dpd}	-	35	ns	
DAC_SDIN Setup Time Before SCLK Rising Edge	t_{ds}	3	-	ns	
DAC_SDIN Hold Time After SCLK Rising Edge	t_{dh}	5	-	ns	
DAC_SDIN Hold Time After SCLK Rising Edge	t_{dh1}	5	-	ns	
ADC_SDOUT Hold Time After SCLK Rising Edge	t_{dh2}	10	-	ns	
ADC_SDOUT Valid Before SCLK Rising Edge	t_{dval}	15	-	ns	
Master Mode					
Output Sample Rate (LRCK) All Speed Modes	F_s	-	MCLK / 256	kHz	
LRCK Duty Cycle		45	55	%	
SCLK Frequency		-	64 x F_s	MHz	
SCLK Duty Cycle		45	55	%	
LRCK Edge to SCLK Rising Edge	t_{lcks}	-	5	ns	
SCLK Falling Edge to ADC_SDOUT Output Valid	t_{dpd}	-	35	ns	
DAC_SDIN Setup Time Before SCLK Rising Edge	t_{ds}	3	-	ns	
DAC_SDIN Hold Time After SCLK Rising Edge	t_{dh1}	5	-	ns	

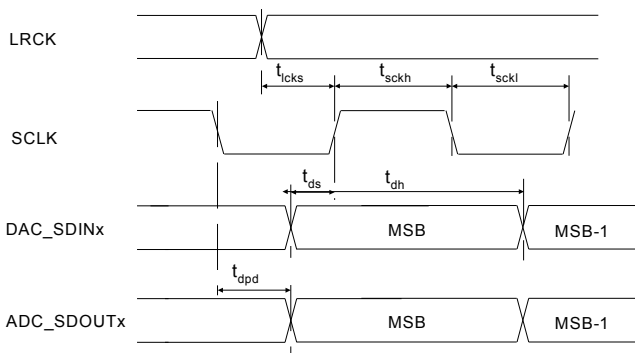

Figure 4. Serial Audio Interface Slave Mode Timing

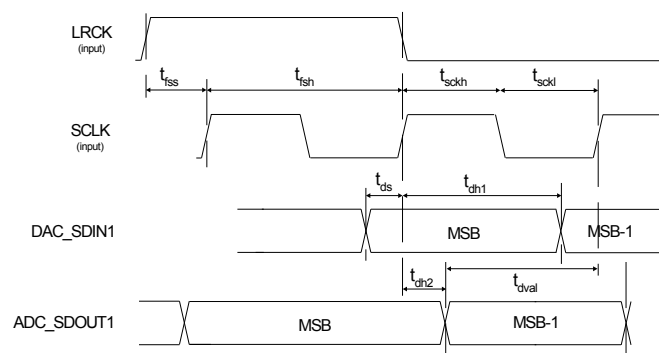

Figure 5. TDM Serial Audio Interface Timing

Notes:

17. After powering up the CS42448, $\overline{\text{RST}}$ should be held low after the power supplies and clocks are settled.
18. See [Table 10 on page 44](#) and [Table 11 on page 45](#) for suggested MCLK frequencies.
19. When operating in TDM interface format, VLS is limited to nominal 2.5 V to 5.0 V operation only.
20. ADC - I²S, Left-Justified, Right-Justified interface formats only. DAC - I²S, Left-Justified, Right-Justified and Time Division Multiplexed interface formats only.
21. "LRCK" and "SCLK" shall refer to the ADC and DAC left/right clock and serial clock, respectively.

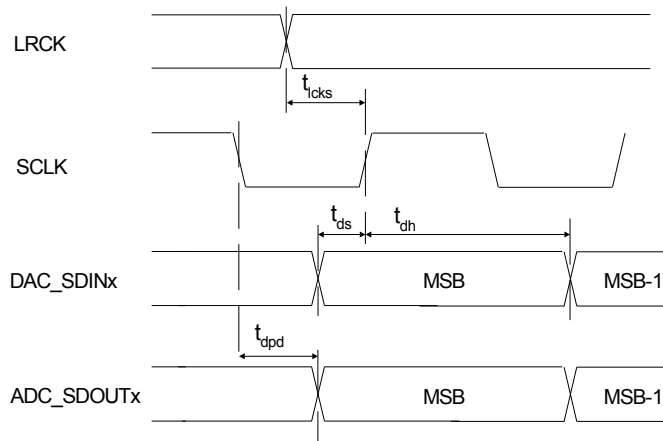

Figure 6. Serial Audio Interface Master Mode Timing

SWITCHING CHARACTERISTICS - AUX PORT

Inputs: Logic 0 = DGND, Logic 1 = VLS.

Parameters	Symbol	Min	Max	Units
Master Mode				
Output Sample Rate (AUX_LRCK) All Speed Modes	F_s	-	ADC_LRCK	kHz
AUX_SCLK Frequency		-	$64 \cdot \text{ADC_LRCK}$	kHz
AUX_SCLK Duty Cycle		45	55	%
AUX_LRCK Edge to SCLK Rising Edge	t_{lcks}	-	5	ns
AUX_SDIN Setup Time Before SCLK Rising Edge	t_{ds}	3	-	ns
AUX_SDIN Hold Time After SCLK Rising Edge	t_{dh}	5	-	ns

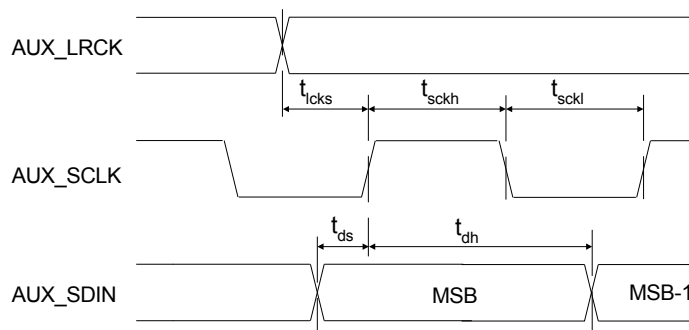

Figure 7. Serial Audio Interface Timing

SWITCHING SPECIFICATIONS - CONTROL PORT - I²C MODE

VLC = 1.8 V - 5.0 V, VLS = VD = 3.3 V, VA = 5.0 V; Inputs: Logic 0 = DGND, Logic 1 = VLC, SDA C_L = 30 pF.

Parameter	Symbol	Min	Max	Unit
SCL Clock Frequency	f _{scl}	-	100	kHz
RST Rising Edge to Start	t _{irs}	500	-	ns
Bus Free Time Between Transmissions	t _{buf}	4.7	-	μs
Start Condition Hold Time (prior to first clock pulse)	t _{hdst}	4.0	-	μs
Clock Low time	t _{low}	4.7	-	μs
Clock High Time	t _{high}	4.0	-	μs
Setup Time for Repeated Start Condition	t _{sust}	4.7	-	μs
SDA Hold Time from SCL Falling (Note 22)	t _{hdd}	0	-	μs
SDA Setup time to SCL Rising	t _{sud}	250	-	ns
Rise Time of SCL and SDA (Note 23)	t _{rc}	-	1	μs
Fall Time SCL and SDA (Note 23)	t _{fc}	-	300	ns
Setup Time for Stop Condition	t _{susp}	4.7	-	μs
Acknowledge Delay from SCL Falling	t _{ack}	300	1000	ns

Notes:

22. Data must be held for sufficient time to bridge the transition time, t_{fc}, of SCL.
23. Guaranteed by design.

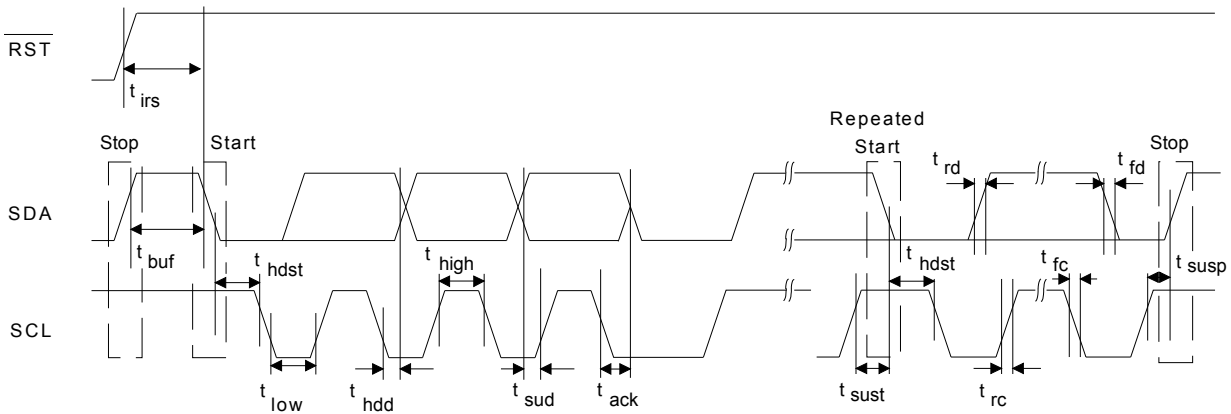

Figure 8. Control Port Timing - I²C Format

SWITCHING SPECIFICATIONS - CONTROL PORT - SPI FORMAT

VLC = 1.8 V - 5.0 V, VLS = VD = 3.3 V, VA = 5.0 V; Inputs: Logic 0 = DGND, Logic 1 = VLC, CDOUT C_L = 30 pF.

Parameter	Symbol	Min	Max	Units
CCLK Clock Frequency	f_{sck}	0	6.0	MHz
RST Rising Edge to \overline{CS} Falling	t_{srs}	20	-	ns
\overline{CS} Falling to CCLK Edge	t_{css}	20	-	ns
\overline{CS} High Time Between Transmissions	t_{csh}	1.0	-	μ s
CCLK Low Time	t_{scl}	66	-	ns
CCLK High Time	t_{sch}	66	-	ns
CDIN to CCLK Rising Setup Time	t_{dsu}	40	-	ns
CCLK Rising to DATA Hold Time	(Note 24) t_{dh}	15	-	ns
CCLK Falling to CDOUT Stable	t_{pd}	-	50	ns
Rise Time of CDOUT	t_{r1}	-	25	ns
Fall Time of CDOUT	t_{f1}	-	25	ns
Rise Time of CCLK and CDIN	(Note 25) t_{r2}	-	100	ns
Fall Time of CCLK and CDIN	(Note 25) t_{f2}	-	100	ns

Notes:

24. Data must be held for sufficient time to bridge the transition time of CCLK.

25. For $f_{sck} < 1$ MHz.

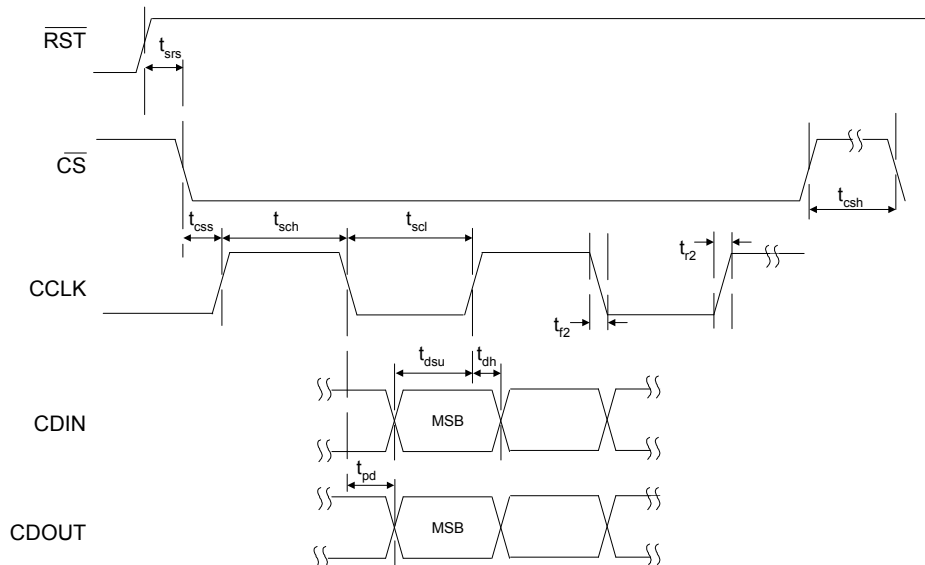

Figure 9. Control Port Timing - SPI Format

DC ELECTRICAL CHARACTERISTICS

AGND = 0 V; all voltages with respect to ground.

Parameters	Symbol	Min	Typ	Max	Units
Normal Operation (Note 26)					
Power Supply Current	I_A	-	80	-	mA
	I_{DT}	-	60.6	-	mA
Power Dissipation		-	600	850	mW
Power Supply Rejection Ratio (Note 28)	PSRR	-	60	-	dB
		-	40	-	dB
Power-Down Mode (Note 29)					
Power Dissipation		-	1.25	-	mW
VQ Characteristics					
Nominal Voltage		-	0.5•VA	-	V
Output Impedance		-	23	-	kΩ
DC Current Source/Sink (Note 30)		-	-	10	μA
FILT+_ADC Nominal Voltage		-	VA	-	V
FILT+_DAC Nominal Voltage		-	VA	-	V

Notes:

26. Normal operation is defined as $\overline{RST} = HI$ with a 997 Hz, 0 dBFS input to the DAC and AUX port, and a 1 kHz, -1 dB analog input to the ADC port sampled at the highest F_s for each speed mode. DAC outputs are open, unless otherwise specified.
27. I_{DT} measured with no external loading on pin 64 (SDA).
28. Valid with the recommended capacitor values on FILT+ and VQ. Increasing the capacitance will also increase the PSRR.
29. Power-Down Mode is defined as $\overline{RST} = LO$ with all clocks and data lines held static and no analog input.
30. Guaranteed by design. The DC current draw represents the allowed current draw from the VQ pin due to typical leakage through the electrolytic de-coupling capacitors.

DIGITAL INTERFACE SPECIFICATIONS & CHARACTERISTICS

Parameters (Note 31)		Symbol	Min	Typ	Max	Units
High-Level Output Voltage at $I_o=2$ mA	Serial Port	V_{OH}	VLS-1.0	-	-	V
	Control Port		VLC-1.0	-	-	V
	MUTECH		VA-1.0	-	-	V
Low-Level Output Voltage at $I_o=2$ mA	Serial Port	V_{OL}	-	-	0.4	V
	Control Port		-	-	0.4	V
	MUTECH		-	-	0.4	V
High-Level Output Voltage at $I_o=100$ μ A	Serial Port	V_{OH}	0.8xVLS	-	-	V
	Control Port		0.8xVLC	-	-	V
	MUTECH		0.8xVA	-	-	V
Low-Level Output Voltage at $I_o=100$ μ A	Serial Port	V_{OL}	-	-	0.2xVLS	V
	Control Port		-	-	0.2xVLC	V
	MUTECH		-	-	0.2xVA	V
High-Level Input Voltage	Serial Port	V_{IH}	0.7xVLS	-	-	V
	Control Port		0.7xVLC	-	-	V
Low-Level Input Voltage	Serial Port	V_{IL}	-	-	0.2xVLS	V
	Control Port		-	-	0.2xVLC	V
Leakage Current		I_{in}	-	-	± 10	μ A
Input Capacitance (Note 23)			-	-	10	pF
MUTECH Drive Current			-	3	-	mA

Notes:

31. See “Digital I/O Pin Characteristics” on page 8 for serial and control port power rails.

4. APPLICATIONS

4.1 Overview

The CS42448 is a highly integrated mixed signal 24-bit audio CODEC comprised of 6 analog-to-digital converters (ADC) implemented using multi-bit delta-sigma techniques and 8 digital-to-analog converters (DAC) also implemented using multi-bit delta-sigma techniques.

Other functions integrated within the CODEC include independent digital volume controls for each DAC, digital de-emphasis filters for the DAC, digital volume control with gain on each ADC channel, ADC high-pass filters, an on-chip voltage reference, and Popguard technology that minimizes the effects of output transients on power-up and power-down.

All serial data is transmitted through two independent serial ports: the DAC serial port and the ADC serial port. Each serial port can be configured independently to operate at different sample and clock rates, but both must run synchronous to each other.

The serial audio interface ports allow up to 8 DAC channels and 8 ADC channels in a Time-Division Multiplexed (TDM) interface format. In the One-Line Mode (OLM) interface format, the CS42448 will allow up to 6 ADC channels on one data line and up to 8 DAC channels on 2 data lines.

The CS42448 features an Auxiliary Port used to accommodate an additional two channels of PCM data on the ADC_SDOOUT data line in the TDM digital interface format. See

for details.

The CS42448 operates in one of three oversampling modes based on the input sample rate. When operating the CODEC as a slave, mode selection is determined automatically based on the MCLK frequency setting. When operating as a master, mode selection is determined by the ADC and DAC FM bits in register [“Functional Mode \(Address 03h\)” on page 44](#). Single-Speed Mode (SSM) supports input sample rates up to 50 kHz and uses a 128x oversampling ratio. Double-Speed Mode (DSM) supports input sample rates up to 100 kHz and uses an oversampling ratio of 64x. Quad-Speed Mode (QSM) supports input sample rates up to 200 kHz and uses an oversampling ratio of 32x (**Note:** QSM for the ADC is only supported in the I²S, Left-Justified, Right-Justified interface formats. QSM for the DAC is supported in the I²S, Left-Justified, Right-Justified and Time Division Multiplexed interface formats).

All functions can be configured through software via a serial control port operable in SPI Mode or in I²C Mode.

[Figure 2 on page 16](#) shows the recommended connections for the CS42448. See [“Register Description” on page 42](#) for the default register settings and options.

4.2 Analog Inputs

4.2.1 Line-Level Inputs

AINx+ and AINx- are the line-level differential analog inputs internally biased to V_Q, approximately V_A/2. [Figure 10 on page 26](#) shows the full-scale analog input levels. The CS42448 also accommodates single-ended signals on all inputs, AIN1-AIN6. See [“ADC Input Filter” on page 54](#) for the recommended input filters.

For single-ended operation on ADC1-ADC3 (AIN1 to AIN6), the ADCx_SINGLE bit in the register [“ADC Control & DAC De-Emphasis \(Address 05h\)” on page 46](#) must be set appropriately (see [Figure 27 on page 54](#) for required external components).

The gain/attenuation of the signal can be adjusted for each AINx independently through the “AINX Volume Control (Address 11h-16h)” on page 51.

The ADC output data is in 2’s complement binary format. For differential inputs above positive full scale or below negative full scale, the ADC will output 7FFFFFFH or 800000H, respectively, and cause the ADC Overflow bit in the register “Status (Address 19h) (Read Only)” on page 52 to be set to a ‘1’. For single-ended inputs, the analog input level must remain at or below full scale to avoid wraparound of the resulting ADC codes. The ADC Overflow bit is reserved in single-ended mode.

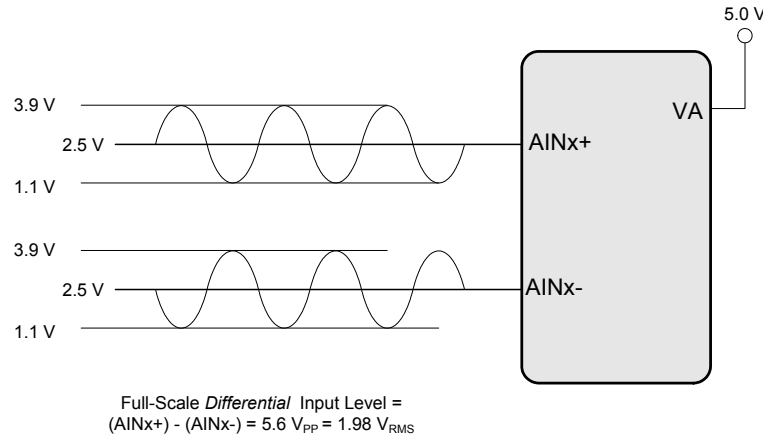

Figure 10. Full-Scale Input

4.2.2 ADC3 Analog Input

ADC3 accommodates differential as well as single-ended inputs. In Single-Ended Mode, an internal MUX selects from up to four single-ended inputs.

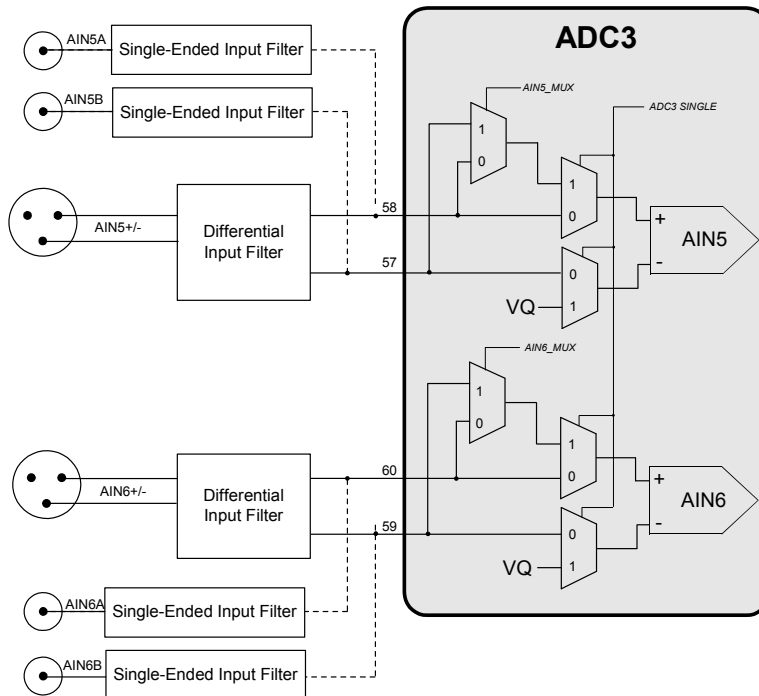

Figure 11. ADC3 Input Topology

Single-Ended Mode is selected using the ADC3_SINGLE bit. Analog input selection is then made via the AINx_MUX bits. See register “ADC Control & DAC De-Emphasis (Address 05h)” on page 46 for all bit selections. Refer to Figure 13 on page 30 for the internal ADC3 analog input topology.

4.2.3 High-Pass Filter and DC Offset Calibration

The high-pass filter continuously subtracts a measure of the DC offset from the output of the decimation filter. If the high-pass filter is disabled during normal operation, the current value of the DC offset for the corresponding channel is frozen and this DC offset will continue to be subtracted from the conversion result. This feature makes it possible to perform a system DC offset calibration by:

1. Running the CS42448 with the high-pass filter enabled until the filter settles. See the Digital Filter Characteristics for filter settling time.
2. Disabling the high-pass filter and freezing the stored DC offset.

The high-pass filter for ADC1/ADC2 can be enabled and disabled. The high pass filter for ADC3 can be independently enabled and disabled. The high-pass filters are controlled using the HPF_FREEZE bit in the register “ADC Control & DAC De-Emphasis (Address 05h)” on page 46.

4.3 Analog Outputs

4.3.1 Initialization

The initialization and Power-Down sequence flow chart is shown in Figure 12 on page 28. The CS42448 enters a power-down state upon initial power-up. The interpolation and decimation filters, delta-sigma modulators and control port registers are reset. The internal voltage reference, multi-bit digital-to-analog and analog-to-digital converters and switched-capacitor low-pass filters are powered down.

The device remains in the power-down state until the $\overline{\text{RST}}$ pin is brought high. The control port is accessible once $\overline{\text{RST}}$ is high, and the desired register settings can be loaded per the interface descriptions in the “Control Port Description and Timing” on page 36.

Once MCLK is valid, VQ will ramp up to VA/2, and the internal voltage references, FILT+_ADC and FILT+_DAC, will begin powering up to normal operation. Power is applied to the D/A converters and switched-capacitor filters, and the analog outputs are clamped to the quiescent voltage, VQ. Once LRCK is valid, MCLK occurrences are counted over one LRCK period to determine the MCLK/LRCK frequency ratio. After an approximate 2000 sample period delay, normal operation begins.

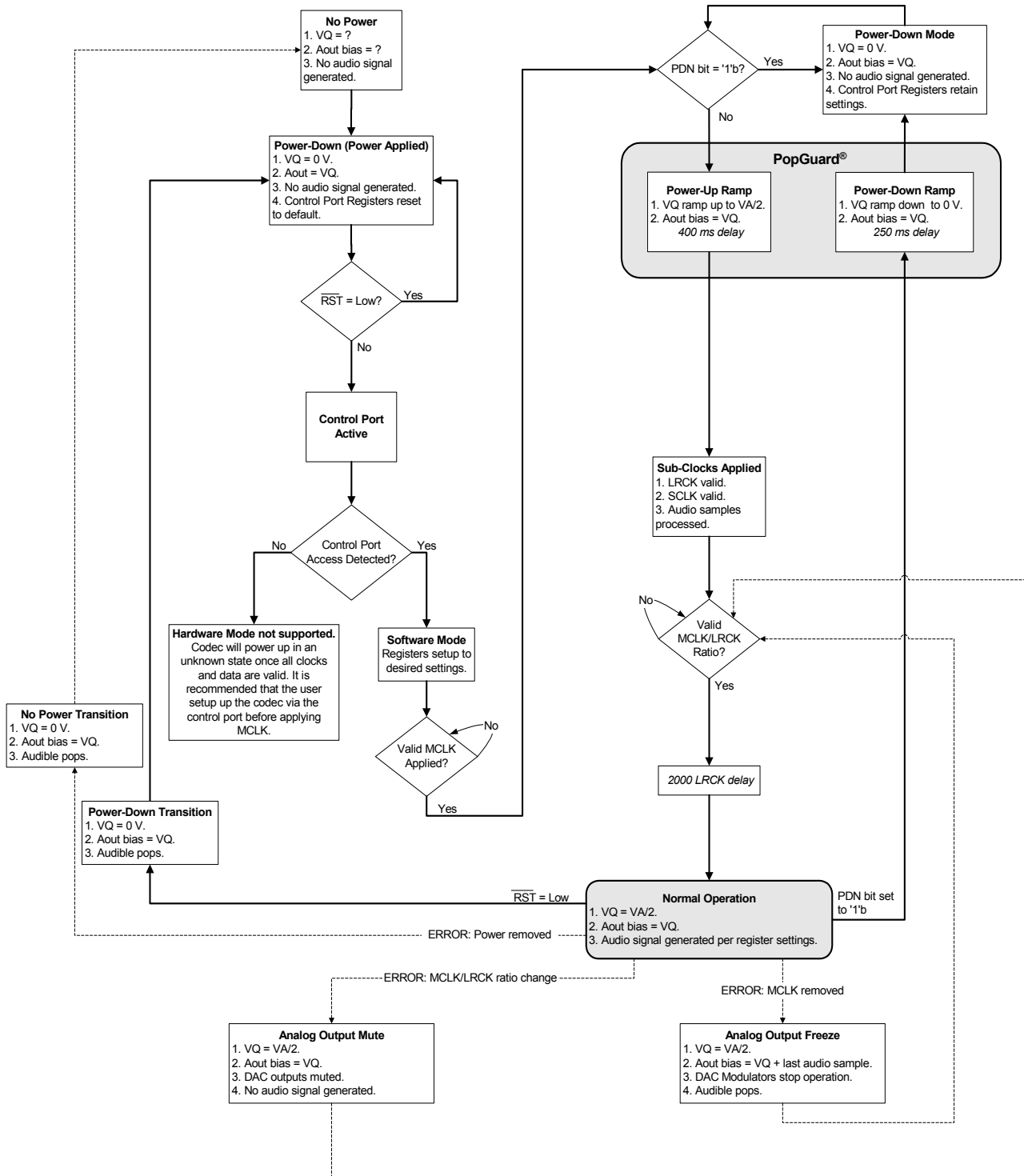
Figure 12. Audio Output Initialization Flow Chart

4.3.2 Output Transient Control

The CS42448 uses Popguard technology to minimize the effects of output transients during power-up and power-down. This technique eliminates the audio transients commonly produced by single-ended single-supply converters when it is implemented with external DC-blocking capacitors connected in series with the audio outputs. To make best use of this feature, it is necessary to understand its operation. See [“Popguard” on page 29](#) for details.

A Mute Control pin is also available for use with an optional mute circuit to mask output transients on the analog outputs. See [“Mute Control” on page 29](#) for details.

When changing clock ratio or sample rate, it is recommended that zero data (or near zero data) be present on DAC_SDINx for at least 10 LRCK samples before the change is made. During the clocking change, the DAC outputs will always be in a zero-data state. If no zero audio is present at the time of switching, a slight click or pop may be heard as the DAC output automatically goes to its zero-data state.

4.3.3 Popguard

4.3.3.1 Power-Up

When the device is initially powered up, the audio outputs, AOUTxx, are clamped to VQ which is initially low. After the $\overline{\text{RST}}$ pin is brought high and MCLK is applied, the outputs begin to ramp with VQ towards the nominal quiescent voltage. This ramp takes approximately 400 ms to complete. The gradual voltage ramping allows time for the external DC-blocking capacitors to charge to VQ, effectively blocking the quiescent DC voltage. Once valid DAC_LRCK, DAC_SCLK and DAC_SDINx are applied, audio output begins approximately 2000 sample periods later.

4.3.3.2 Power-Down

To prevent audio transients at power-down, the DC-blocking capacitors must fully discharge before turning off the power. In order to do this, the PDN bit in register [“Power Control \(Address 02h\)” on page 43](#) must be set to ‘1’ for a period of about 250 ms before removing power. During this time, voltage on VQ and the audio outputs discharge gradually to AGND. If power is removed before this 250 ms time period has passed, a transient will occur when the VA supply drops below that of VQ. There is no minimum time for a power cycle. Power may be re-applied at any time.

4.3.4 Mute Control

The Mute Control pin, MUTEC, is typically connected to an external mute control circuit. The use of external mute circuits is not mandatory, but may be desired for designs requiring the absolute minimum in extraneous clicks and pops.

MUTEC is in high-impedance mode during power up or when the CS42448 enters Power-Down Mode by setting the PDN bit in the register [“Power Control \(Address 02h\)” on page 43](#) to a ‘1’. Once out of Power-Down Mode, the pin can be controlled by the user via the control port (see [“MUTEC Pin Control \(Address 1Bh\)” on page 53](#)) or automatically asserted to the active state when zero data is present on all DAC inputs, when all DAC outputs are muted, or when serial port clock errors occur.

To prevent large transients on the output, it is recommended to mute the DAC outputs before the Mute Control pin is asserted.

4.3.5 Line-Level Outputs and Filtering

The CS42448 contains on-chip buffer amplifiers capable of producing line-level differential as well as single-ended outputs on AOUT1-AOUT8. These amplifiers are biased to a quiescent DC level of approximately V_Q.

The delta-sigma conversion process produces high-frequency noise beyond the audio passband, most of which is removed by the on-chip analog filters. The remaining out-of-band noise can be attenuated using an off-chip low-pass filter.

See “DAC Output Filter” on page 57 for recommended output filter. The active filter configuration accounts for the normally differing AC loads on the AOUTx+ and AOUTx- differential output pins. Also shown is a passive filter configuration which minimizes costs and the number of components.

Figure 13 shows the full-scale analog output levels. All outputs are internally biased to V_Q, approximately V_A/2.

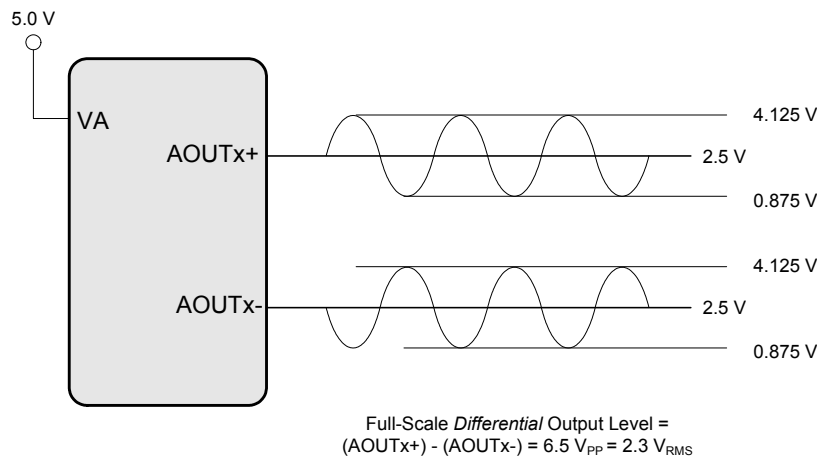

Figure 13. Full-Scale Output

4.3.6 Digital Volume Control

Each DAC’s output level is controlled via the Volume Control registers operating over the range of 0 to -127.5 dB attenuation with 0.5 dB resolution. See “AOUTX Volume Control (Addresses 08h- 0Fh)” on page 50. Volume control changes are programmable to ramp in increments of 0.125 dB at the rate controlled by the SZC[1:0] bits in the Digital Volume Control register. See “Transition Control (Address 06h)” on page 48.

Each output can be independently muted via mute control bits in the register “DAC Channel Mute (Address 07h)” on page 50. When enabled, each AOUTx_MUTE bit attenuates the corresponding DAC to its maximum value (-127.5 dB). When the AOUTx_MUTE bit is disabled, the corresponding DAC returns to the attenuation level set in the Volume Control register. The attenuation is ramped up and down at the rate specified by the SZC[1:0] bits.

4.3.7 De-Emphasis Filter

The CS42448 includes on-chip digital de-emphasis optimized for a sample rate of 44.1 kHz. The filter response is shown in Figure 14. The de-emphasis feature is included to accommodate audio recordings that utilize 50/15 μs pre-emphasis equalization as a means of noise reduction.

De-emphasis is only available in Single-Speed Mode. Please see [“DAC De-Emphasis Control \(DAC_DEM\)” on page 47](#) for de-emphasis control.

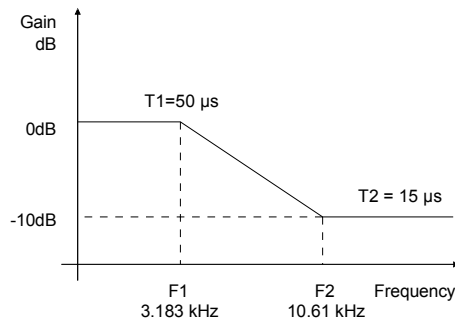

Figure 14. De-Emphasis Curve

4.4 System Clocking

The CODEC (ADC & DAC) serial audio interface ports operate either as a slave or master. The serial ports accept externally generated clocks in slave mode and will generate synchronous clocks derived from an input master clock in master mode. In the TDM format the ADC and DAC serial ports will only operate as a slave. In OLM #2 the serial ports will accept or output a 256Fs SCLK. See the registers [“DAC Functional Mode \(DAC_FM\[1:0\]\)” on page 44](#) and [“ADC Functional Mode \(ADC_FM\[1:0\]\)” on page 44](#) for setting up master/slave mode.

The CODEC requires external generation of the master clock (MCLK). The frequency of this clock must be an integer multiple of, and synchronous with, the system sample rate, Fs.

The required integer ratios, along with some common frequencies, are illustrated in tables [Tables 2 to 4](#). The frequency range of MCLK must be specified using the MFREQ bits in register [“MCLK Frequency \(MFREQ\[2:0\]\)” on page 44](#).

Sample Rate (kHz)	MCLK (MHz)		
	256x	512x	1024x
32	8.1920	16.3840	32.7680
44.1	11.2896	22.5792	45.1584
48	12.2880	24.5760	49.1520

Table 2. Single-Speed Mode Common Frequencies

Sample Rate (kHz)	MCLK (MHz)		
	128x	256x	512x
64	8.1920	16.3840	32.7680
88.2	11.2896	22.5792	45.1584
96	12.2880	24.5760	49.1520

Table 3. Double-Speed Mode Common Frequencies

Sample Rate (kHz)	MCLK (MHz)		
	64x	128x	256x
176.4	11.2896	22.5792	45.1584
192	12.2880	24.5760	49.1520

Table 4. Quad-Speed Mode Common Frequencies

4.5 CODEC Digital Interface Formats

The ADC and DAC serial ports support the I²S, Left-Justified, Right-Justified, One-Line Mode (OLM) and TDM digital interface formats with varying bit depths from 16 to 32 as shown in [Figures 15-19](#). Data is clocked out of the ADC on the falling edge of SCLK and clocked into the DAC on the rising edge. The serial bit clock, DAC_SCLK and/or ADC_SCLK, must be synchronously derived from the master clock and be equal to 256x, 128x, 64x, 48x or 32x Fs, depending on the interface format selected and desired speed mode. One-Line Mode #1 and One-Line Mode #2 will operate in master or slave mode. Refer to [Table 5](#) for required clock ratios. The SCLK to sample rate (LRCK) ratios are shown in [Tables 5 through 8](#).

Ratio	I ² S, Left-Justified, Right-Justified		
	SSM	DSM	QSM
MCLK/LRCK	256x, 512x, 1024x	128x, 256x, 512x	64x, 128x, 256x
SCLK/LRCK (Slave Mode)	32x, 48x, 64x	32x, 48x, 64x	32x, 48x, 64x
SCLK/LRCK (Master Mode)	64x	64x	64x

Table 5. I²S, LJ, RJ Clock Ratios

Ratio	OLM #1		
	SSM	DSM	QSM
MCLK/LRCK	256x, 512x, 1024x	256x, 512x	N/A
SCLK/LRCK (Slave Mode)	128x	128x	N/A
SCLK/LRCK (Master Mode)	128x	128x	N/A

Table 6. OLM #1 Clock Ratios

Ratio	OLM #2		
	SSM	DSM	QSM
MCLK/LRCK	256x, 512x, 1024x	256x, 512x	N/A
SCLK/LRCK (Slave Mode)	256x	256x	N/A
SCLK/LRCK (Master Mode)	256x	256x	N/A

Table 7. OLM #2 Clock Ratios

Ratio	TDM		
	SSM	DSM	QSM (DAC only)
MCLK/LRCK	256x, 512x, 1024x	256x, 512x	256x
SCLK/LRCK (Slave Mode)	256x	256x	256x
SCLK/LRCK (Master Mode)	N/A	N/A	N/A

Table 8. TDM Clock Ratios

4.5.1 I²S

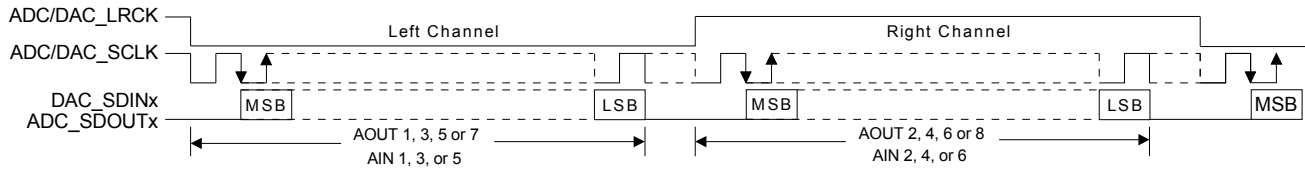

Figure 15. I²S Format

4.5.2 Left-Justified

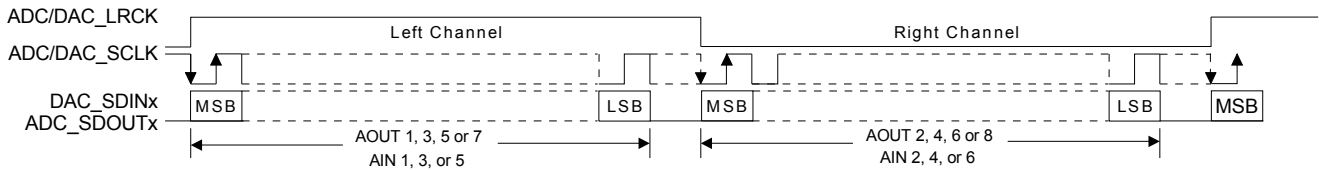

Figure 16. Left Justified Format

4.5.3 Right-Justified

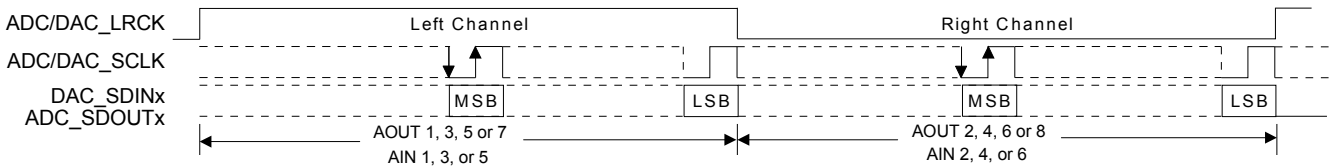

Figure 17. Right Justified Format

4.5.4 OLM #1

OLM #1 serial audio interface format operates in Single- or Double-Speed Mode only and will master or slave ADC/DAC_SCLK at 128 Fs.

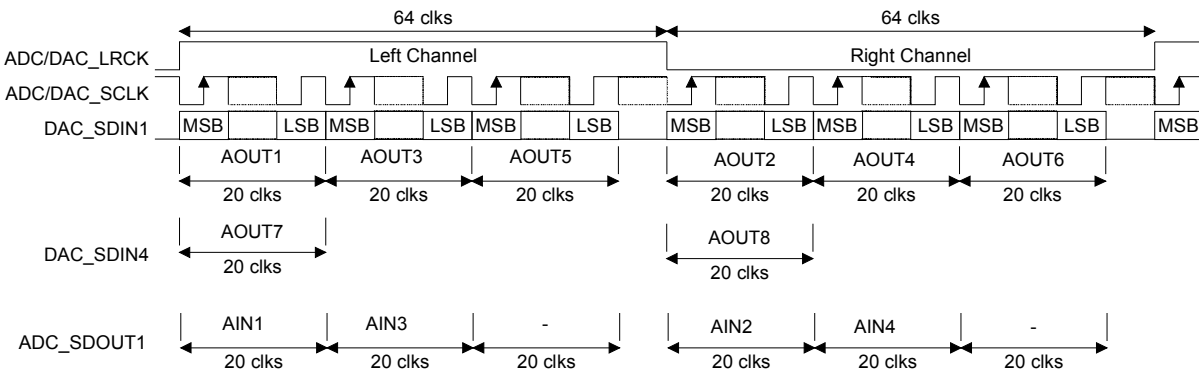

Figure 18. One-Line Mode #1 Format

4.5.5 OLM #2

OLM #2 serial audio interface format operates in Single- or Double-Speed Mode and will master or slave ADC/DAC_SCLK at 256Fs.

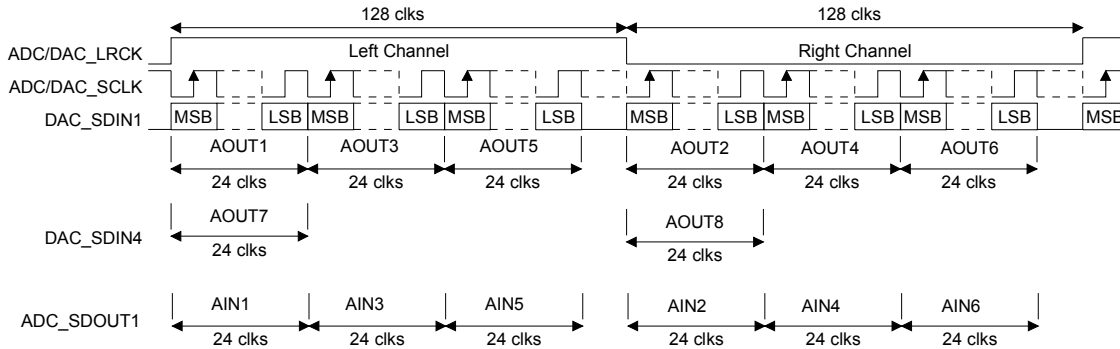

Figure 19. One Line Mode #2 Format

4.5.6 TDM

TDM data is received most significant bit (MSB) first, on the second rising edge of the DAC_SCLK occurring after a DAC_LRCK rising edge. All data is valid on the rising edge of DAC_SCLK. The AIN1 MSB is transmitted early, but is guaranteed valid for a specified time after SCLK rises. All other bits are transmitted on the falling edge of ADC_SCLK. Each time slot is 32 bits wide, with the valid data sample left 'justified' within the time slot. Valid data lengths are 16, 18, 20, or 24.

ADC/DAC_SCLK must operate at 256Fs. ADC/DAC_LRCK identifies the start of a new frame and is equal to the sample rate, Fs.

ADC/DAC_LRCK is sampled as valid on the rising ADC/DAC_SCLK edge preceding the most significant bit of the first data sample and must be held valid for at least 1 ADC/DAC_SCLK period.

Note: The ADC does not meet the timing requirements for proper operation in Quad-Speed Mode.

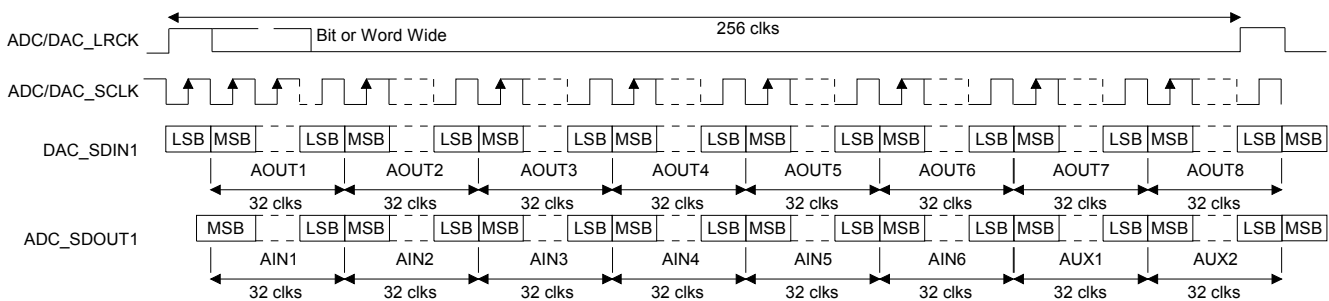

Figure 20. TDM Format

4.5.7 I/O Channel Allocation

Digital Input/Output	Interface Format	Analog Output/Input Channel Allocation from/to Digital I/O
DAC_SDIN1	I ² S, LJ, RJ OLM TDM	AOUT 1,2 AOUT 1,2,3,4,5,6 AOUT 1,2,3,4,5,6,7,8
DAC_SDIN2	I ² S, LJ, RJ OLM TDM	AOUT 3,4 Not Used Not Used
DAC_SDIN3	I ² S, LJ, RJ OLM TDM	AOUT 5,6 Not Used Not Used
DAC_SDIN4	I ² S, LJ, RJ OLM TDM	AOUT 7,8 AOUT 7,8 Not Used
ADC_SDOOUT1	I ² S, LJ, RJ OLM TDM	AIN 1,2 AIN 1,2,3,4,5,6 AIN 1,2,3,4,5,6; (2 additional channels from AUX_SDIN)
ADC_SDOOUT2	I ² S, LJ, RJ OLM TDM	AIN 3,4 Not Used Not Used
ADC_SDOOUT3	I ² S, LJ, RJ OLM TDM	AIN 5,6 Not Used Not Used

Table 9. Serial Audio Interface Channel Allocations

4.6 AUX Port Digital Interface Formats

These serial data lines are used when supporting the TDM Mode of operation with an external ADC or S/PDIF receiver attached. The AUX serial port operates only as a clock master. The AUX_SCLK will operate at 64x F_s , where F_s is equal to the ADC sample rate (ADC_LRCK). If the AUX_SDIN signal is not being used, it should be tied to AGND via a pull-down resistor.

The AUX port will operate in either the Left-Justified or I²S digital interface format with bit depths ranging from 16 to 24 bits. Settings for the AUX port are made through the register "[Interface Formats \(Address 04h\)](#)" on page 45.

4.6.1 I²S

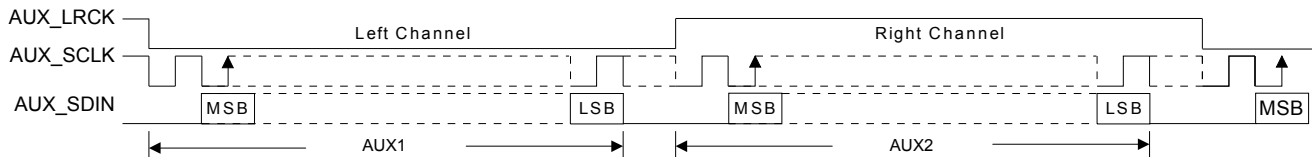

Figure 21. AUX I²S Format

4.6.2 Left-Justified

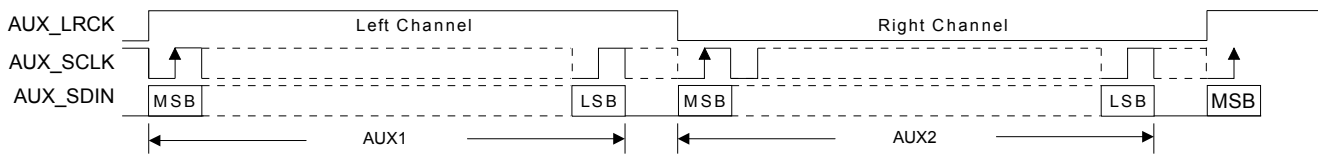

Figure 22. AUX Left-Justified Format

4.7 Control Port Description and Timing

The control port is used to access the registers allowing the CS42448 to be configured for the desired operational modes and formats. The operation of the control port may be completely asynchronous with respect to the audio sample rates. However, to avoid potential interference problems, the control port pins should remain static if no operation is required.

The control port has two modes: SPI and I²C, with the CS42448 acting as a slave device. SPI Mode is selected if there is a high-to-low transition on the AD0/ \overline{CS} pin, after the \overline{RST} pin has been brought high. I²C Mode is selected by connecting the AD0/ \overline{CS} pin through a resistor to VLC or DGND, thereby permanently selecting the desired AD0 bit address state.

4.7.1 SPI Mode

In SPI Mode, \overline{CS} is the CS42448 chip-select signal, CCLK is the control port bit clock (input into the CS42448 from the microcontroller), CDIN is the input data line from the microcontroller, CDOUT is the output data line to the microcontroller. Data is clocked in on the rising edge of CCLK and out on the falling edge.

Figure 23 shows the operation of the control port in SPI Mode. To write to a register, bring \overline{CS} low. The first seven bits on CDIN form the chip address and must be 1001111. The eighth bit is a read/write indicator (R/W), which should be low to write. The next eight bits form the Memory Address Pointer (MAP), which is set to the address of the register that is to be updated. The next eight bits are the data which will be placed into the register designated by the MAP. During writes, the CDOUT output stays in the Hi-Z state. It may be externally pulled high or low with a 47 k Ω resistor, if desired.

There is a MAP auto-increment capability, enabled by the INCR bit in the MAP register. If INCR is a zero, the MAP will stay constant for successive read or writes. If INCR is set to a 1, the MAP will auto-increment after each byte is read or written, allowing block reads or writes of successive registers.

To read a register, the MAP has to be set to the correct address by executing a partial write cycle which finishes (\overline{CS} high) immediately after the MAP byte. The MAP auto-increment bit (INCR) may be set or not, as desired. To begin a read, bring \overline{CS} low, send out the chip address and set the read/write bit (R/W) high. The next falling edge of CCLK will clock out the MSB of the addressed register (CDOUT will leave the high impedance state). If the MAP auto-increment bit is set to 1, the data for successive registers will appear consecutively.

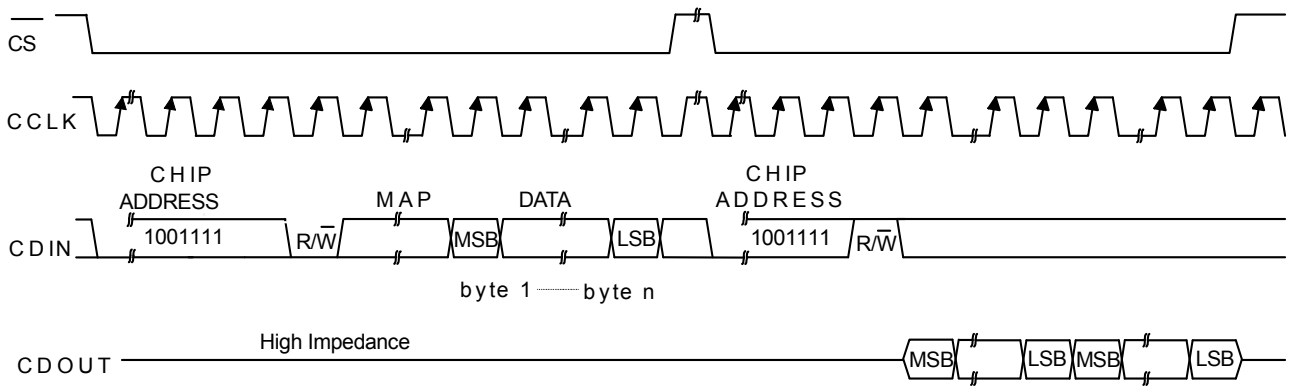

MAP = Memory Address Pointer, 8 bits, MSB first

Figure 23. Control Port Timing in SPI Mode

4.7.2 I²C Mode

In I²C Mode, \overline{SDA} is a bidirectional data line. Data is clocked into and out of the part by the clock, \overline{SCL} . There is no \overline{CS} pin. Pins AD0 and AD1 form the two least-significant bits of the chip address and should be connected through a resistor to VLC or DGND as desired. The state of the pins is sensed while the CS42448 is being reset.

The signal timings for a read and write cycle are shown in Figure 24 and Figure 25. A Start condition is defined as a falling transition of \overline{SDA} while the clock is high. A Stop condition is a rising transition while the clock is high. All other transitions of \overline{SDA} occur while the clock is low. The first byte sent to the CS42448 after a Start condition consists of a 7-bit chip address field and a R/W bit (high for a read, low for a write). The upper 5 bits of the 7-bit address field are fixed at 10010. To communicate with a CS42448, the chip address field, which is the first byte sent to the CS42448, should match 10010 followed by the settings of the AD1 and AD0. The eighth bit of the address is the R/W bit. If the operation is a write, the next byte is the Memory Address Pointer (MAP) which selects the register to be read or written. If the operation is a read, the contents of the register pointed to by the MAP will be output. Setting the auto-increment bit in MAP allows successive reads or writes of consecutive registers. Each byte is separated by an acknowledge bit. The ACK bit is output from the CS42448 after each input byte is read, and is input to the CS42448 from the microcontroller after each transmitted byte.

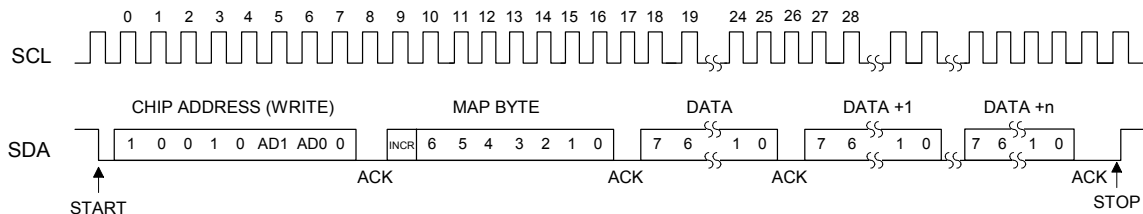

Figure 24. Control Port Timing, I²C Write

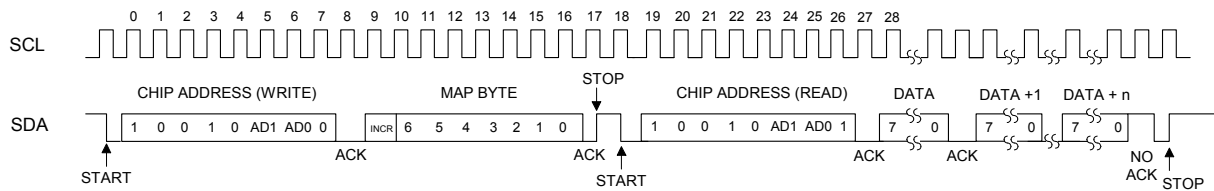

Figure 25. Control Port Timing, I²C Read

Since the read operation cannot set the MAP, an aborted write operation is used as a preamble. As shown in [Figure 25](#), the write operation is aborted after the acknowledge for the MAP byte by sending a stop condition. The following pseudocode illustrates an aborted write operation followed by a read operation.

Send start condition.

Send 10010xx0 (chip address & write operation).

Receive acknowledge bit.

Send MAP byte, auto increment off.

Receive acknowledge bit.

Send stop condition, aborting write.

Send start condition.

Send 10010xx1(chip address & read operation).

Receive acknowledge bit.

Receive byte, contents of selected register.

Send acknowledge bit.

Send stop condition.

Setting the auto-increment bit in the MAP allows successive reads or writes of consecutive registers. Each byte is separated by an acknowledge bit.

4.8 Interrupts

The CS42448 has a comprehensive interrupt capability. The INT output pin is intended to drive the interrupt input pin on the host microcontroller. The INT pin may be configured as an active low or active high CMOS driver or an open-drain driver. This last mode is used for active low, wired-OR hook-ups, with multiple peripherals connected to the microcontroller interrupt input pin.

Many conditions can cause an interrupt, as listed in the interrupt status register descriptions. See [“Status \(Address 19h\) \(Read Only\)” on page 52](#). Each source may be masked off through mask register bits. In addition, each source may be set to rising edge, falling edge, or level sensitive. Combined with the option of level sensitive or edge sensitive modes within the microcontroller, many different configurations are possible, depending on the needs of the system designer.

4.9 Recommended Power-Up Sequence

1. Hold $\overline{\text{RST}}$ low until the power supply and clocks are stable. In this state, the control port is reset to its default settings and VQ will remain low.
2. Bring $\overline{\text{RST}}$ high. The device will initially be in a low power state with VQ low. All features will default as described in the “[Register Quick Reference](#)” on page 40.
3. Perform a write operation to the Power Control register (“[Power Control \(Address 02h\)](#)” on page 43) to set bit 0 to a ‘1’b. This will place the device in a power down state.
4. Load the desired register settings while keeping the PDN bit set to ‘1’b.
5. Mute all DACs. Muting the DACs suppresses any noise associated with the CODEC’s first initialization after power is applied.
6. Set the PDN bit in the power control register to ‘0’b. VQ will ramp to approximately VA/2 according to the Popguard specification in section “[Popguard](#)” on page 29.
7. Following approximately 2000 LRCK cycles, the device is initialized and ready for normal operation.
8. After the CODEC is initialized, wait ~90 LRCK cycles (~1.9 ms @48 kHz) and then un-mute the DACs.
9. Normal operation begins.

4.10 Reset and Power-Up

It is recommended that reset be activated if the analog or digital supplies drop below the recommended operating condition to prevent power-glitch-related issues.

The delta-sigma modulators settle in a matter of microseconds after the analog section is powered, either through the application of power or by setting the $\overline{\text{RST}}$ pin high. However, the voltage reference will take much longer to reach a final value due to the presence of external capacitance on the ADC/DAC_FILT+ pins. A time delay of approximately 400 ms is required after applying power to the device or after exiting a reset state. During this voltage reference ramp delay, all serial ports and DAC outputs will be automatically muted.

4.11 Power Supply, Grounding, and PCB Layout

As with any high-resolution converter, the CS42448 requires careful attention to power supply and grounding arrangements if its potential performance is to be realized. [Figure 2](#) shows the recommended power arrangements, with VA connected to clean supplies. VD, which powers the digital circuitry, may be run from the system logic supply. Alternatively, VD may be powered from the analog supply via a ferrite bead. In this case, no additional devices should be powered from VD.

Extensive use of power and ground planes, ground plane fill in unused areas and surface mount decoupling capacitors are recommended. Decoupling capacitors should be placed as close to the pins of the CS42448 as possible. The low value ceramic capacitor should be closest to the pin and should be mounted on the same side of the board as the CS42448 to minimize inductance effects. All signals, especially clocks, should be kept away from the ADC/DAC_FILT+, VQ pins in order to avoid unwanted coupling into the modulators. The ADC/DAC_FILT+ and VQ decoupling capacitors, particularly the 0.1 μF , must be positioned to minimize the electrical path from ADC/DAC_FILT+ and AGND. The CS42448 evaluation board demonstrates the optimum layout and power supply arrangements.

For optimal heat dissipation from the package, it is recommended that the area directly under the part be filled with copper and tied to the ground plane. The use of vias connecting the topside ground to the backside ground is also recommended.

5. REGISTER QUICK REFERENCE

Note: The default value in all “Reserved” registers must be preserved.

Addr	Function	7	6	5	4	3	2	1	0
01h	ID p 42 default	Chip_ID3 0	Chip_ID2 0	Chip_ID1 0	Chip_ID0 0	Rev_ID3 0	Rev_ID2 0	Rev_ID1 0	Rev_ID0 1
02h	Power Control p 43 default	PDN_ADC3 0	PDN_ADC2 0	PDN_ADC1 0	PDN_DAC4 0	PDN_DAC3 0	PDN_DAC2 0	PDN_DAC1 0	PDN 0
03h	Functional Mode p 44 default	DAC_FM1 1	DAC_FM0 1	ADC_FM1 1	ADC_FM0 1	MFREQ2 0	MFREQ1 0	MFREQ0 0	Reserved 0
04h	Interface Formats p 45 default	FREEZE 0	AUX_DIF 0	DAC_DIF2 1	DAC_DIF1 1	DAC_DIF0 0	ADC_DIF2 1	ADC_DIF1 1	ADC_DIF0 0
05h	ADC Control (w/DAC_DEM) p 46 default	ADC1-2_HPF FREEZE 0	ADC3_HPF FREEZE 0	DAC_DEM 0	ADC1 SINGLE 0	ADC2 SINGLE 0	ADC3 SINGLE 0	AIN5_MUX 0	AIN6_MUX 0
06h	Transition Control p 48 default	DAC_SNG VOL 0	DAC_SZC1 0	DAC_SZC0 0	AMUTE 1	MUTE ADC_SP 0	ADC_SNG VOL 0	ADC_SZC1 0	ADC_SZC0 0
07h	Channel Mute p 50 default	AOUT8 MUTE 0	AOUT7 MUTE 0	AOUT6 MUTE 0	AOUT5 MUTE 0	AOUT4 MUTE 0	AOUT3 MUTE 0	AOUT2 MUTE 0	AOUT1 MUTE 0
08h	Vol. Control AOUT1 p 50 default	AOUT1 VOL7 0	AOUT1 VOL6 0	AOUT1 VOL5 0	AOUT1 VOL4 0	AOUT1 VOL3 0	AOUT1 VOL2 0	AOUT1 VOL1 0	AOUT1 VOL0 0
09h	Vol. Control AOUT2 p 50 default	AOUT2 VOL7 0	AOUT2 VOL6 0	AOUT2 VOL5 0	AOUT2 VOL4 0	AOUT2 VOL3 0	AOUT2 VOL2 0	AOUT2 VOL1 0	AOUT2 VOL0 0
0Ah	Vol. Control AOUT3 p 50 default	AOUT3 VOL7 0	AOUT3 VOL6 0	AOUT3 VOL5 0	AOUT3 VOL4 0	AOUT3 VOL3 0	AOUT3 VOL2 0	AOUT3 VOL1 0	AOUT3 VOL0 0
0Bh	Vol. Control AOUT4 p 50 default	AOUT4 VOL7 0	AOUT4 VOL6 0	AOUT4 VOL5 0	AOUT4 VOL4 0	AOUT4 VOL3 0	AOUT4 VOL2 0	AOUT4 VOL1 0	AOUT4 VOL0 0
0Ch	Vol. Control AOUT5 p 50 default	AOUT5 VOL7 0	AOUT5 VOL6 0	AOUT5 VOL5 0	AOUT5 VOL4 0	AOUT5 VOL3 0	AOUT5 VOL2 0	AOUT5 VOL1 0	AOUT5 VOL0 0
0Dh	Vol. Control AOUT6 p 50 default	AOUT6 VOL7 0	AOUT6 VOL6 0	AOUT6 VOL5 0	AOUT6 VOL4 0	AOUT6 VOL3 0	AOUT6 VOL2 0	AOUT6 VOL1 0	AOUT6 VOL0 0
0Eh	Vol. Control AOUT7 p 50 default	AOUT7 VOL7 0	AOUT7 VOL6 0	AOUT7 VOL5 0	AOUT7 VOL4 0	AOUT7 VOL3 0	AOUT7 VOL2 0	AOUT7 VOL1 0	AOUT7 VOL0 0
0Fh	Vol. Control AOUT8 p 50 default	AOUT8 VOL7 0	AOUT8 VOL6 0	AOUT8 VOL5 0	AOUT8 VOL4 0	AOUT8 VOL3 0	AOUT8 VOL2 0	AOUT8 VOL1 0	AOUT8 VOL0 0
10h	DAC Channel Invert p 51 default	INV_AOUT8 0	INV_AOUT7 0	INV_AOUT6 0	INV_AOUT5 0	INV_AOUT4 0	INV_AOUT3 0	INV_AOUT2 0	INV_AOUT1 0

Addr	Function	7	6	5	4	3	2	1	0
11h	Vol. Control AIN1 p 50 default	AIN1 VOL7 0	AIN1 VOL6 0	AIN1 VOL5 0	AIN1 VOL4 0	AIN1 VOL3 0	AIN1 VOL2 0	AIN1 VOL1 0	AIN1 VOL0 0
12h	Vol. Control AIN2 p 51 default	AIN2 VOL7 0	AIN2 VOL6 0	AIN2 VOL5 0	AIN2 VOL4 0	AIN2 VOL3 0	AIN2 VOL2 0	AIN2 VOL1 0	AIN2 VOL0 0
13h	Vol. Control AIN3 p 50 default	AIN3 VOL7 0	AIN3 VOL6 0	AIN3 VOL5 0	AIN3 VOL4 0	AIN3 VOL3 0	AIN3 VOL2 0	AIN3 VOL1 0	AIN3 VOL0 0
14h	Vol. Control AIN4 p 51 default	AIN4 VOL7 0	AIN4 VOL6 0	AIN4 VOL5 0	AIN4 VOL4 0	AIN4 VOL3 0	AIN4 VOL2 0	AIN4 VOL1 0	AIN4 VOL0 0
15h	Vol. Control AIN5 p 50 default	AIN5 VOL7 0	AIN5 VOL6 0	AIN5 VOL5 0	AIN5 VOL4 0	AIN5 VOL3 0	AIN5 VOL2 0	AIN5 VOL1 0	AIN5 VOL0 0
16h	Vol. Control AIN6 p 51 default	AIN6 VOL7 0	AIN6 VOL6 0	AIN6 VOL5 0	AIN6 VOL4 0	AIN6 VOL3 0	AIN6 VOL2 0	AIN6 VOL1 0	AIN6 VOL0 0
17h	ADC Chan- nel Invert p 51 default	Reserved 0	Reserved 0	INV_A6 0	INV_A5 0	INV_A4 0	INV_A3 0	INV_A2 0	INV_A1 0
18h	Status Con- trol p 52 default	Reserved 0	Reserved 0	Reserved 0	Reserved 0	INT1 0	INT0 0	Reserved 0	Reserved 0
19h	Status p 52 default	Reserved 0	Reserved 0	Reserved 0	DAC_CLK Error X	ADC_CLK Error X	ADC3 OVFL X	ADC2 OVFL X	ADC1 OVFL X
1Ah	Status Mask p 53 default	Reserved 0	Reserved 0	Reserved 0	DAC_CLK Error_M 0	ADC_CLK Error_M 0	ADC3 OVFL_M 0	ADC2 OVFL_M 0	ADC1 OVFL_M 0
1Bh	MUTE C p 53 default	Reserved 0	Reserved 0	Reserved 0	Reserved 0	Reserved 0	Reserved 0	MCPolarity 0	MUTE C Active 0

6. REGISTER DESCRIPTION

All registers are read/write except for the I.D. and Revision Register and Interrupt Status Register which are read only. See the following bit-definition tables for bit assignment information. The default state of each bit after a power-up sequence or reset is listed in each bit description.

6.1 Memory Address Pointer (MAP)

Not a register

7	6	5	4	3	2	1	0
INCR	MAP6	MAP5	MAP4	MAP3	MAP2	MAP1	MAP0

6.1.1 Increment (INCR)

Default = 1

Function:

Memory address pointer auto increment control

0 - MAP is not incremented automatically.

1 - Internal MAP is automatically incremented after each read or write.

6.1.2 Memory Address Pointer (MAP[6:0])

Default = 0000001

Function:

Memory address pointer (MAP). Sets the register address that will be read or written by the control port.

6.2 Chip I.D. and Revision Register (Address 01h) (Read Only)

7	6	5	4	3	2	1	0
Chip_ID3	Chip_ID2	Chip_ID1	Chip_ID0	Rev_ID3	Rev_ID2	Rev_ID1	Rev_ID0

6.2.1 Chip I.D. (CHIP_ID[3:0])

Default = 0000

Function:

I.D. code for the CS42448. Permanently set to 0000.

6.2.2 Chip Revision (REV_ID[3:0])

Default = 0001

Function:

CS42448 revision level. Revision A is coded as 0001.

6.3 Power Control (Address 02h)

7	6	5	4	3	2	1	0
PDN_ADC3	PDN_ADC2	PDN_ADC1	PDN_DAC4	PDN_DAC3	PDN_DAC2	PDN_DAC1	PDN

6.3.1 Power Down ADC Pairs (PDN_ADCX)

Default = 0

0 - Disable

1 - Enable

Function:

When enabled, the respective ADC channel pair (ADC1 - AIN1/AIN2; ADC2 - AIN3/AIN4; and ADC3 - AIN5/AIN6) will remain in a reset state.

6.3.2 Power Down DAC Pairs (PDN_DACX)

Default = 0

0 - Disable

1 - Enable

Function:

When enabled, the respective DAC channel pair (DAC1 - AOUT1/AOUT2; DAC2 - AOUT3/AOUT4; DAC3 - AOUT5/AOUT6; and DAC4 - AOUT7/AOUT8) will remain in a reset state. It is advised that any change of these bits be made while the DACs are muted or the power down bit (PDN) is enabled to eliminate the possibility of audible artifacts.

6.3.3 Power Down (PDN)

Default = 0

0 - Disable

1 - Enable

Function:

The entire device will enter a low-power state when this function is enabled. The contents of the control registers are retained in this mode.

6.4 Functional Mode (Address 03h)

7	6	5	4	3	2	1	0
DAC_FM1	DAC_FM0	ADC_FM1	ADC_FM0	MFreq2	MFreq1	MFreq0	Reserved

6.4.1 DAC Functional Mode (DAC_FM[1:0])

Default = 11

Master Mode

00 - Single-Speed Mode (4 to 50 kHz sample rates)

01 - Double-Speed Mode (50 to 100 kHz sample rates)

10 - Quad-Speed Mode (100 to 200 kHz sample rates)

Slave Mode

11 - (Auto-detect sample rates)

Function:

Selects the required range of sample rates for the DAC serial port.

6.4.2 ADC Functional Mode (ADC_FM[1:0])

Default = 11

Master Mode

00 - Single-Speed Mode (4 to 50 kHz sample rates)

01 - Double-Speed Mode (50 to 100 kHz sample rates)

10 - Quad-Speed Mode (100 to 200 kHz sample rates)

Slave Mode

11 - (Auto-detect sample rates)

Function:

Selects the required range of sample rates for the ADC serial port.

6.4.3 MCLK Frequency (MFREQ[2:0])

Default = 000

Function:

Sets the appropriate frequency for the supplied MCLK. For TDM and OLM #2 operation, ADC/DAC_SCLK must equal 256Fs. For OLM #1 operation, ADC/DAC_SCLK must equal 128Fs. MCLK can be equal to or greater than the higher frequency of ADC_SCLK or DAC_SCLK.

				Ratio (xFs)		
MFreq2	MFreq1	MFreq0	Description	SSM	DSM	QSM
0	0	0	1.0290 MHz to 12.8000 MHz	256	128	64
0	0	1	Reserved			
0	1	0	2.0480 MHz to 25.6000 MHz	512	256	128
0	1	1	Reserved			
1	X	X	4.0960 MHz to 51.2000 MHz	1024	512	256

Table 10. MCLK Frequency Settings for I²S, Left and Right Justified Interface Formats

				Ratio (xFs)		
MFreq2	MFreq1	MFreq0	Description	SSM	DSM	QSM
0	0	0	1.0290 MHz to 12.8000 MHz	256	N/A	N/A
0	0	1	Reserved			
0	1	0	2.0480 MHz to 25.6000 MHz	512	256	N/A
0	0	1	Reserved			
1	X	X	4.0960 MHz to 51.2000 MHz	1024	512	256

Table 11. MCLK Frequency Settings for TDM & OLM Interface Formats

6.5 Interface Formats (Address 04h)

7	6	5	4	3	2	1	0
FREEZE	AUX_DIF	DAC_DIF2	DAC_DIF1	DAC_DIF0	ADC_DIF2	ADC_DIF1	ADC_DIF0

6.5.1 Freeze Controls (FREEZE)

Default = 0

Function:

This function will freeze the previous settings of, and allow modifications to be made to the channel mutes, the DAC and ADC Volume Control/Channel Invert registers without the changes taking effect until the FREEZE is disabled. To have multiple changes in these control port registers take effect simultaneously, enable the FREEZE bit, make all register changes, then disable the FREEZE bit.

6.5.2 Auxiliary Digital Interface Format (AUX_DIF)

Default = 0

0 - Left Justified
1 - I²S

Function:

This bit selects the digital interface format used for the AUX Serial Port. The required relationship between the Left/Right clock, serial clock and serial data is defined by the Digital Interface Format and the options are detailed in [Figures 23-24](#).

6.5.3 DAC Digital Interface Format (DAC_DIF[2:0])

Default = 110

Function:

These bits select the digital interface format used for the DAC Serial Port. The required relationship between the Left/Right clock, serial clock and serial data is defined by the Digital Interface Format; the options are detailed in the section “CODEC Digital Interface Formats” on page 32.

Refer to [Table 9](#), “Serial Audio Interface Channel Allocations,” on page 35.

DAC_DIF2	DAC_DIF1	DAC_DIF0	Description	Format	Figure
0	0	0	Left Justified, up to 24-bit data	0	Figure 16
0	0	1	I ² S, up to 24-bit data	1	Figure 15
0	1	0	Right Justified, 24-bit data	2	Figure 17

Table 12. DAC Digital Interface Formats

DAC_DIF2	DAC_DIF1	DAC_DIF0	Description	Format	Figure
0	1	1	Right Justified, 16-bit data	3	Figure 17
1	0	0	One-Line #1, 20-bit	4	Figure 18
1	0	1	One-Line #2, 24-bit	5	Figure 19
1	1	0	TDM Mode, 24-bit (slave only)	6	Figure 20
1	1	1	Reserved	-	-

Table 12. DAC Digital Interface Formats

6.5.4 ADC Digital Interface Format (ADC_DIF[2:0])

Default = 110

Function:

These bits select the digital interface format used for the ADC serial port. The required relationship between the Left/Right clock, serial clock and serial data is defined by the Digital Interface Format and the options are detailed in the section “CODEC Digital Interface Formats” on page 32. Refer to [Table 9, “Serial Audio Interface Channel Allocations,”](#) on page 35.

Note: The ADC does not meet Quad-Speed Mode timing specifications in the TDM interface format.

ADC_DIF2	ADC_DIF1	ADC_DIF0	Description	Format	Figure
0	0	0	Left Justified, up to 24-bit data	0	Figure 16
0	0	1	I ² S, up to 24-bit data	1	Figure 15
0	1	0	Right Justified, 24-bit data	2	Figure 17
0	1	1	Right Justified, 16-bit data	3	Figure 17
1	0	0	One-Line #1, 20-bit	4	Figure 18
1	0	1	One-Line #2, 24-bit	5	Figure 19
1	1	0	TDM Mode, 24-bit (slave only)	6	Figure 20
1	1	1	Reserved	-	-

Table 13. ADC Digital Interface Formats

6.6 ADC Control & DAC De-Emphasis (Address 05h)

7	6	5	4	3	2	1	0
ADC1-2_HPF FREEZE	ADC3_HPF FREEZE	DAC_DEM	ADC1 SINGLE	ADC2 SINGLE	ADC3 SINGLE	AIN5_MUX	AIN6_MUX

6.6.1 ADC1-2 High-Pass Filter Freeze (ADC1-2_HPF FREEZE)

Default = 0

Function:

When this bit is set, the internal high-pass filter will be disabled for ADC1 and ADC2. The current DC offset value will be frozen and continue to be subtracted from the conversion result. See “[ADC Digital Filter Characteristics](#)” on page 13.

6.6.2 **ADC3 High Pass Filter Freeze (ADC3_HPFFREEZE)**

Default = 0

Function:

When this bit is set, the internal high-pass filter will be disabled for ADC3. The current DC offset value will be frozen and continue to be subtracted from the conversion result. See [“ADC Digital Filter Characteristics” on page 13](#).

6.6.3 **DAC De-Emphasis Control (DAC_DEM)**

Default = 0

0 - No De-Emphasis

1 - De-Emphasis Enabled (Auto-Detect Fs)

Function:

Enables the digital filter to maintain the standard 15 μ s/50 μ s digital de-emphasis filter response at the auto-detected sample rate of either 32, 44.1, or 48 kHz. De-emphasis will not be enabled, regardless of this register setting, at any other sample rate.

6.6.4 **ADC1 Single-Ended Mode (ADC1_SINGLE)**

Default = 0

0 - Disabled; Differential input to ADC1

1 - Enabled; Single-Ended input to ADC1

Function:

When enabled, this bit allows the user to apply a single-ended input to the positive terminal of ADC1. A +6 dB digital gain is automatically applied to the serial audio data of ADC1. The negative leg must be driven to the common mode of the ADC. See [Figure 27 on page 54](#) for a graphical description, and Sections [4.2.1](#) and [6.14.3](#).

6.6.5 **ADC2 Single-Ended Mode (ADC2_SINGLE)**

Default = 0

0 - Disabled; Differential input to ADC2

1 - Enabled; Single-Ended input to ADC2

Function:

When enabled, this bit allows the user to apply a single-ended input to the positive terminal of ADC2. A +6 dB digital gain is automatically applied to the serial audio data of ADC2. The negative leg must be driven to the common mode of the ADC. See [Figure 27 on page 54](#) for a graphical description, and Sections [4.2.1](#) and [6.14.3](#).

6.6.6 *ADC3 Single-Ended Mode (ADC3 SINGLE)*

Default = 0

- 0 - Disabled; Differential input to ADC
- 1 - Enabled; Single-Ended input to ADC

Function:

When disabled, this bit removes the 4:2 multiplexer from the signal path of ADC3 allowing a differential input. When enabled, this bit allows the user to choose between four single-ended inputs to ADC3, using the AIN5_MUX and AIN6_MUX bits. See [Figure 27 on page 54](#) for a graphical description, and Sections [4.2.1](#) and [6.14.3](#).

6.6.7 *Analog Input Ch. 5 Multiplexer (AIN5_MUX)*

Default = 0

- 0 - Single-Ended Input AIN5A
- 1 - Single-Ended Input AIN5B

Function:

ADC3 can accept single-ended input signals when the ADC3 SINGLE bit is enabled. The AIN5_MUX bit selects between two input channels (AIN5A or AIN5B) to be sent to ADC3 in Single-Ended Mode. This bit is ignored when the ADC3_SINGLE bit is disabled. See [Figure 27 on page 54](#) for a graphical description, and Sections [4.2.1](#) and [6.14.3](#).

6.6.8 *Analog Input Ch. 6 Multiplexer (AIN6_MUX)*

Default = 0

- 0 - Single-Ended Input AIN6A
- 1 - Single-Ended Input AIN6B

Function:

ADC3 can accept a single-ended input signal when the ADC3 SINGLE bit is enabled. The AIN6_MUX bit selects between two input channels (AIN6A or AIN6B) to be sent to ADC3 in Single-Ended Mode. This bit is ignored when the ADC3_SINGLE bit is disabled. See [Figure 27 on page 54](#) for a graphical description, and Sections [4.2.1](#) and [6.14.3](#).

6.7 *Transition Control (Address 06h)*

7	6	5	4	3	2	1	0
DAC_SNGVOL	DAC_SZC1	DAC_SZC0	AMUTE	MUTE ADC_SP	ADC_SNGVOL	ADC_SZC1	ADC_SZC0

6.7.1 *Single Volume Control (DAC_SNGVOL, ADC_SNGVOL)*

Default = 0

Function:

The individual channel volume levels are independently controlled by their respective Volume Control registers when this function is disabled. When enabled, the volume on all channels is determined by the AOUT1 and AIN1 Volume Control register and the other Volume Control registers are ignored.

6.7.2 **Soft Ramp and Zero Cross Control (ADC_SZC[1:0], DAC_SZC[1:0])**

Default = 00

- 00 - Immediate Change
- 01 - Zero Cross
- 10 - Soft Ramp
- 11 - Soft Ramp on Zero Crossings

Function:

Immediate Change

When Immediate Change is selected, all volume-level changes will take effect immediately in one step.

Zero Cross

Zero Cross Enable dictates that signal level changes, either by gain changes, attenuation changes or muting, will occur on a signal zero crossing to minimize audible artifacts. The requested level change will occur after a timeout period between 512 and 1024 sample periods (10.7 ms to 21.3 ms at 48 kHz sample rate) if the signal does not encounter a zero crossing. The zero cross function is independently monitored and implemented for each channel.

Soft Ramp

Soft Ramp allows level changes, either by gain changes, attenuation changes or muting, to be implemented by incrementally ramping, in 1/8 dB steps, from the current level to the new level at a rate of 1 dB per 8 left/right clock periods.

Soft Ramp on Zero Crossing

Soft Ramp and Zero Cross Enable dictates that signal level changes, either by gain changes, attenuation changes or muting, will occur in 1/8 dB steps and be implemented on a signal zero crossing. The 1/8 dB level change will occur after a timeout period between 512 and 1024 sample periods (10.7 ms to 21.3 ms at 48 kHz sample rate) if the signal does not encounter a zero crossing. The zero cross function is independently monitored and implemented for each channel.

6.7.3 **Auto-Mute (AMUTE)**

Default = 1

- 0 - Disabled
- 1 - Enabled

Function:

The Digital-to-Analog converters of the CS42448 will mute the output following the reception of 8192 consecutive audio samples of static 0 or -1. A single sample of non-static data will release the mute. Detection and muting is done independently for each channel. The quiescent voltage on the output will be retained and the MUTE pin will go active during the mute period. The muting function is affected, similar to volume control changes, by the Soft and Zero Cross bits (SZC[1:0]).

6.7.4 Mute ADC Serial Port (MUTE_ADC_SP)

Default = 0

0 - Disabled

1 - Enabled

Function:

When enabled, the ADC Serial Port will be muted.

6.8 DAC Channel Mute (Address 07h)

7	6	5	4	3	2	1	0
AOUT8_MUTE	AOUT7_MUTE	AOUT6_MUTE	AOUT5_MUTE	AOUT4_MUTE	AOUT3_MUTE	AOUT2_MUTE	AOUT1_MUTE

6.8.1 Independent Channel Mute (AOUTX_MUTE)

Default = 0

0 - Disabled

1 - Enabled

Function:

The respective Digital-to-Analog converter outputs of the CS42448 will mute when enabled. The quiescent voltage on the outputs will be retained. The muting function is affected by the DAC Soft and Zero Cross bits (DAC_SZC[1:0]). When all channels are muted, the MUTE pin will become active.

6.9 AOUTX Volume Control (Addresses 08h- 0Fh)

7	6	5	4	3	2	1	0
AOUTx_VOL7	AOUTx_VOL6	AOUTx_VOL5	AOUTx_VOL4	AOUTx_VOL3	AOUTx_VOL2	AOUTx_VOL1	AOUTx_VOL0

6.9.1 Volume Control (AOUTX_VOL[7:0])

Default = 00h

Function:

The AOUTx Volume Control registers allow independent setting of the signal levels in 0.5 dB increments from 0 dB to -127.5 dB. Volume settings are decoded as shown in [Table 14](#). The volume changes are implemented as dictated by the Soft and Zero Cross bits (DAC_SZC[1:0]). All volume settings less than -127.5 dB are equivalent to enabling the AOUTx_MUTE bit for the given channel.

Binary Code	Volume Setting
00000000	0 dB
00101000	-20 dB
01010000	-40 dB
01111000	-60 dB
10110100	-90 dB

Table 14. Example AOUT Volume Settings

6.10 DAC Channel Invert (Address 10h)

7	6	5	4	3	2	1	0
INV_AOUT8	INV_AOUT7	INV_AOUT6	INV_AOUT5	INV_AOUT4	INV_AOUT3	INV_AOUT2	INV_AOUT1

6.10.1 Invert Signal Polarity (INV_AOUTX)

Default = 0

0 - Disabled

1 - Enabled

Function:

When enabled, these bits will invert the signal polarity of their respective channels.

6.11 AINX Volume Control (Address 11h-16h)

7	6	5	4	3	2	1	0
AINx_VOL7	AINx_VOL6	AINx_VOL5	AINx_VOL4	AINx_VOL3	AINx_VOL2	AINx_VOL1	AINx_VOL0

6.11.1 AINX Volume Control (AINX_VOL[7:0])

Default = 00h

Function:

The level of AIN1 - AIN6 can be adjusted in 0.5 dB increments as dictated by the ADC Soft and Zero Cross bits (ADC_SZC[1:0]) from +24 to -64 dB. Levels are decoded in two's complement, as shown in [Table 15](#).

Binary Code	Volume Setting
0111 1111	+24 dB
...	...
0011 0000	+24 dB
...	...
0000 0000	0 dB
1111 1111	-0.5 dB
1111 1110	-1 dB
...	...
1000 0000	-64 dB

Table 15. Example AIN Volume Settings

6.12 ADC Channel Invert (Address 17h)

7	6	5	4	3	2	1	0
Reserved	Reserved	INV_AIN6	INV_AIN5	INV_AIN4	INV_AIN3	INV_AIN2	INV_AIN1

6.12.1 Invert Signal Polarity (INV_AINX)

Default = 0

0 - Disabled

1 - Enabled

Function:

When enabled, these bits will invert the signal polarity of their respective channels.

6.13 Status Control (Address 18h)

7	6	5	4	3	2	1	0
Reserved	Reserved	Reserved	Reserved	INT1	INT0	Reserved	Reserved

6.13.1 Interrupt Pin Control (INT[1:0])

Default = 00

00 - Active high; high output indicates interrupt condition has occurred

01 - Active low, low output indicates an interrupt condition has occurred

10 - Open drain, active low. Requires an external pull-up resistor on the INT pin.

11 - Reserved

Function:

Determines how the Interrupt pin (INT) will indicate an interrupt condition.

For DAC and ADC clock errors, the INT pin is set to “Level Active Mode” and will become active *during* the clock error. For the ADCx_OVFL error, the INT pin is set to Level Active Mode and will become active *during* the overflow error.

6.14 Status (Address 19h) (Read Only)

7	6	5	4	3	2	1	0
Reserved	Reserved	Reserved	DAC_CLK Error	ADC_CLK Error	ADC3_OVFL	ADC2_OVFL	ADC1_OVFL

For all bits in this register, a “1” means the associated error condition has occurred at least once since the register was last read. A “0” means the associated error condition has NOT occurred since the last reading of the register. Reading the register resets all bits to 0. Status bits that are masked off in the associated mask register will always be “0” in this register.

6.14.1 DAC CLOCK ERROR (DAC_CLK ERROR)

Default = x

Function:

Indicates an invalid MCLK to DAC_LRCK ratio. This status flag is set to “Level Active Mode” and becomes active *during* the error condition. See [“System Clocking” on page 31](#) for valid clock ratios.

6.14.2 ADC CLOCK ERROR (ADC_CLK ERROR)

Default = x

Function:

Indicates an invalid MCLK to ADC_LRCK ratio. This status flag is set to “Level Active Mode” and becomes active *during* the error condition. See [“System Clocking” on page 31](#) for valid clock ratios.

6.14.3 ADC Overflow (ADCX_OVFL)

Default = x

Function:

Indicates that there is an over-range condition anywhere in the CS42448 ADC signal path of each of the associated ADCs. This status flag becomes active on the *arrival* of the error condition. This bit is reserved when analog inputs are driven as single-ended.

6.15 Status Mask (Address 1Ah)

7	6	5	4	3	2	1	0
Reserved	Reserved	Reserved	DAC_CLK Error_M	ADC_CLK Error_M	ADC3_OVFL_M	ADC2_OVFL_M	ADC1_OVFL_M

Default = 00000

Function:

The bits of this register serve as a mask for the error sources found in the register “[Status \(Address 19h\) \(Read Only\)](#)” on page 52. If a mask bit is set to 1, the error is unmasked, meaning that its occurrence will affect the INT pin and the status register. If a mask bit is set to 0, the error is masked, meaning that its occurrence will not affect the INT pin or the status register. The bit positions align with the corresponding bits in the Status register.

6.16 MUTE Pin Control (Address 1Bh)

7	6	5	4	3	2	1	0
Reserved	Reserved	Reserved	Reserved	Reserved	Reserved	MCPolarity	MUTE ACTIVE

6.17 MUTE Polarity Select (MCPOLARITY)

Default = 0

- 0 - Active low
- 1 - Active high

Function:

Determines the polarity of the MUTE pin.

6.18 MUTE CONTROL ACTIVE (MUTE ACTIVE)

Default = 0

- 0 - MUTE pin is not active.
- 1 - MUTE pin is active.

Function:

The MUTE pin will go high or low (depending on the MUTE Polarity Select bit) when this bit is enabled.

7. EXTERNAL FILTERS

7.1 ADC Input Filter

The analog modulator samples the input at 6.144 MHz (internal MCLK=12.288 MHz). The digital filter will reject signals within the stopband of the filter. However, there is no rejection for input signals which are multiples of the digital passband frequency ($n \times 6.144$ MHz), where $n=0,1,2,\dots$. Refer to [Figures 26](#) and [27](#) for a recommended analog input filter that will attenuate any noise energy at 6.144 MHz, in addition to providing the optimum source impedance for the modulators. Refer to [Figures 28](#) and [29](#) for low-cost, low-component-count passive input filters. The use of capacitors that have a large voltage coefficient (such as general-purpose ceramics) must be avoided since these can degrade signal linearity

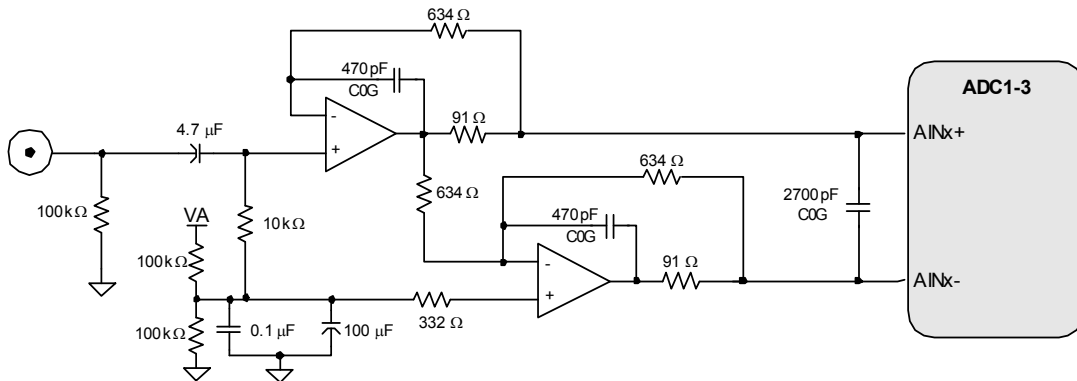

Figure 26. Single to Differential Active Input Filter

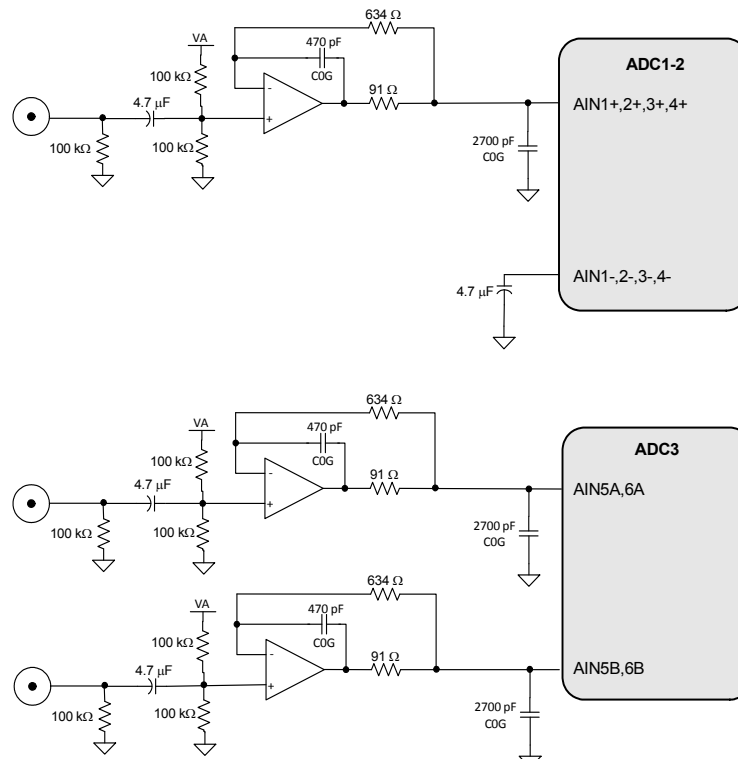

Figure 27. Single-Ended Active Input Filter

7.1.1 Passive Input Filter

The passive filter implementation shown in Figure 28 will attenuate any noise energy at 6.144 MHz but will not provide optimum source impedance for the ADC modulators. Full analog performance will therefore not be realized using a passive filter. Figure 28 illustrates the unity gain, passive input filter solution. In this topology the distortion performance is affected, but the dynamic range performance is not limited.

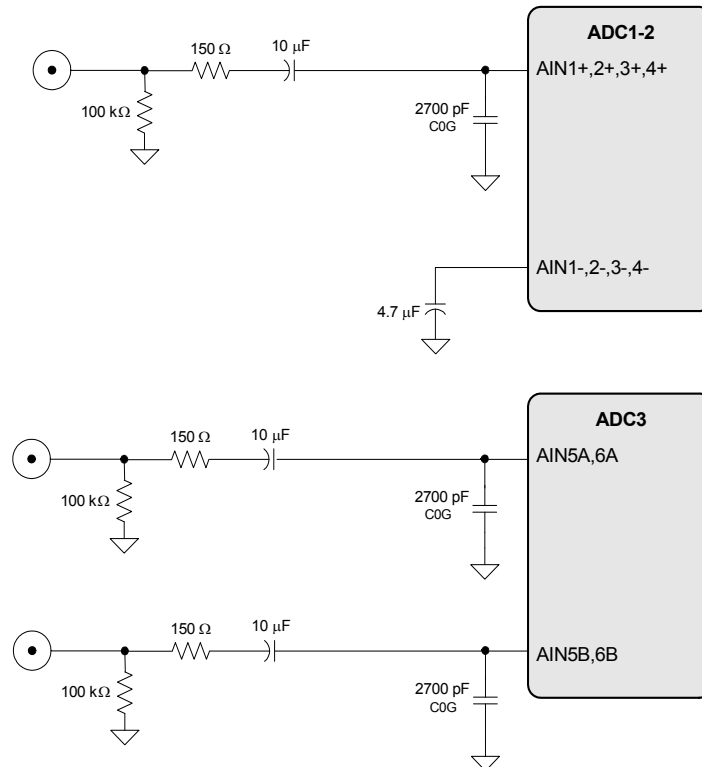

Figure 28. Passive Input Filter

7.1.2 Passive Input Filter w/Attenuation

Some applications may require signal attenuation prior to the ADC. The full-scale input voltage will scale with the analog power supply voltage. For $V_A = 5.0\text{ V}$, the full-scale input voltage is approximately 2.8 Vpp, or 1 Vrms (most consumer audio line-level outputs range from 1.5 to 2 Vrms).

Figure 29 shows a passive input filter with 6 dB of signal attenuation. Due to the relatively high input impedance on the analog inputs, the full distortion performance cannot be realized. Also, the resistor divider circuit will determine the input impedance into the input filter. In the circuit shown in Figure 29, the input impedance is approximately 5 kΩ. By doubling the resistor values, the input impedance will increase to 10 kΩ. However, in this case the distortion performance will drop due to the increase in series resistance on the analog inputs.

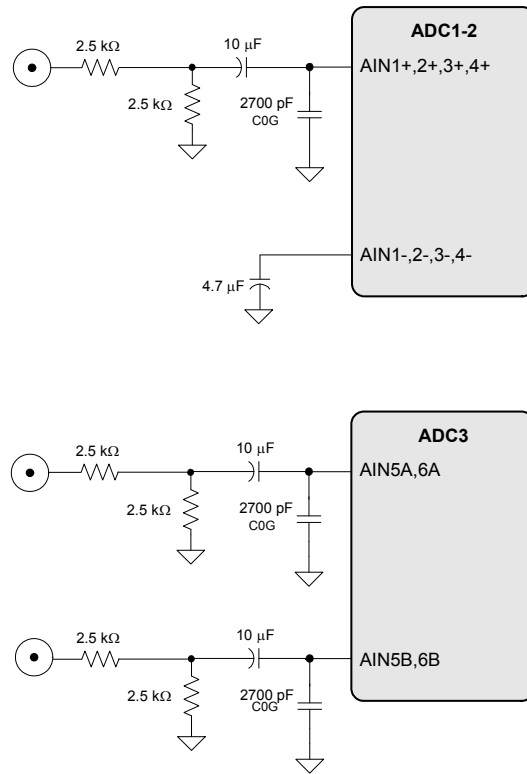

Figure 29. Passive Input Filter w/Attenuation

7.2 DAC Output Filter

Shown below are recommended active and passive output filters.

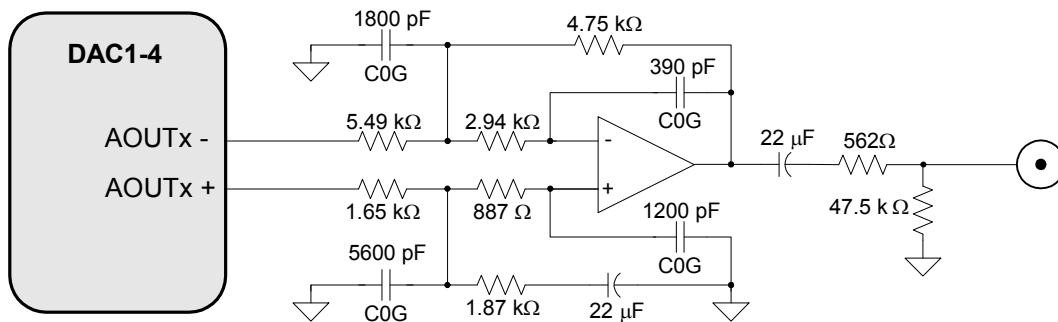

Figure 30. Active Analog Output Filter

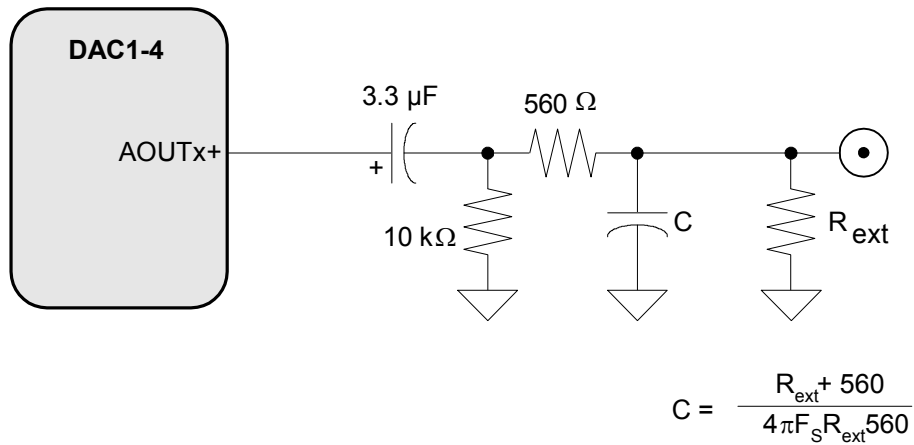

Figure 31. Passive Analog Output Filter

8. ADC FILTER PLOTS

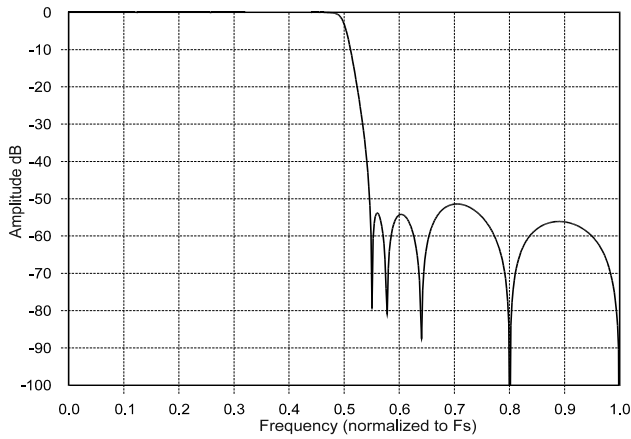

Figure 32. SSM Stopband Rejection

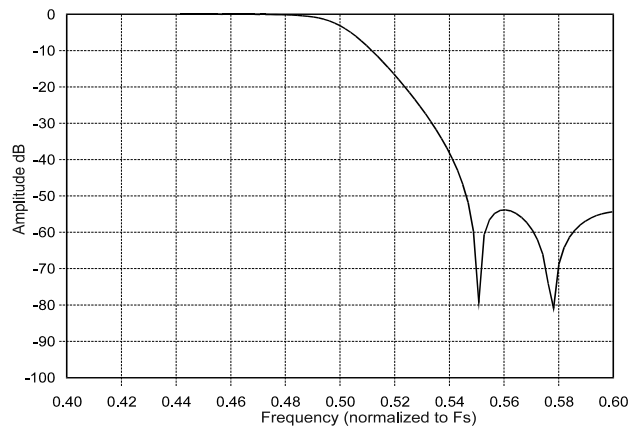

Figure 33. SSM Transition Band

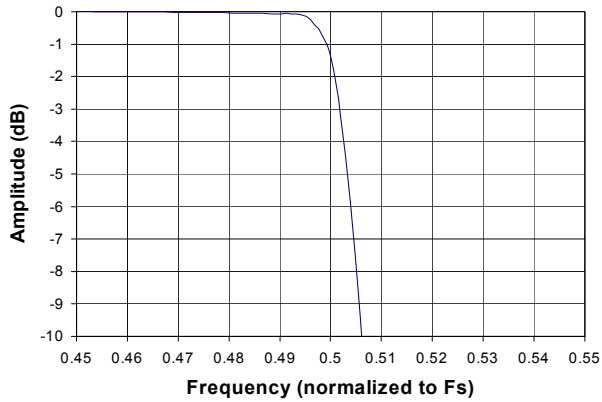

Figure 34. SSM Transition Band (Detail)

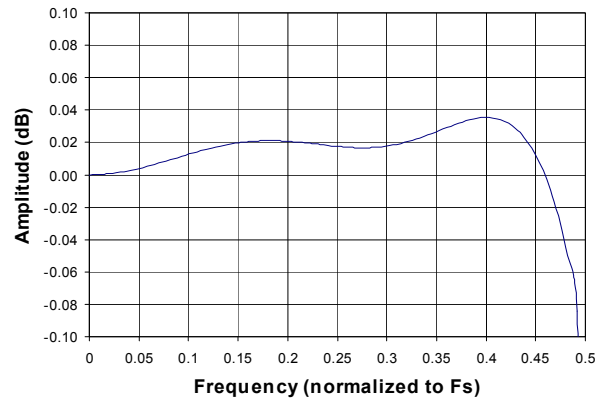

Figure 35. SSM Passband Ripple

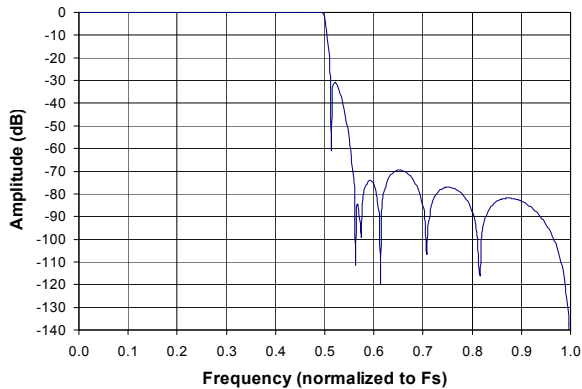

Figure 36. DSM Stopband Rejection

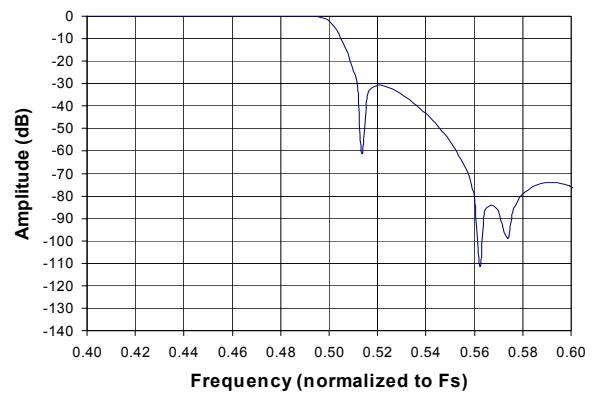
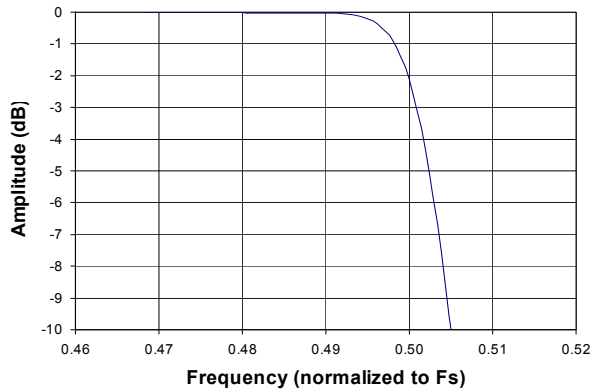
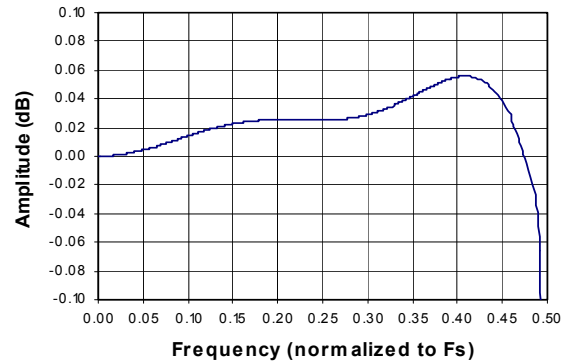
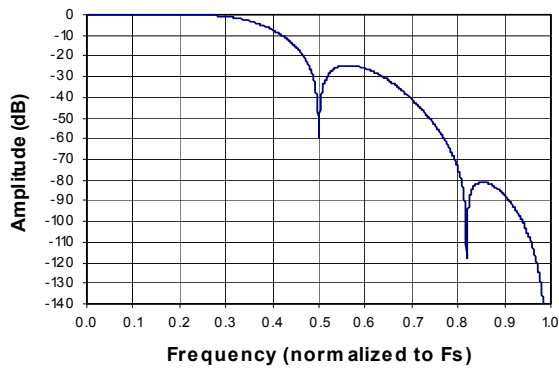
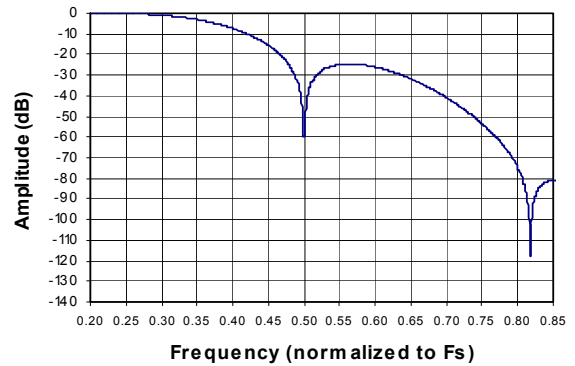
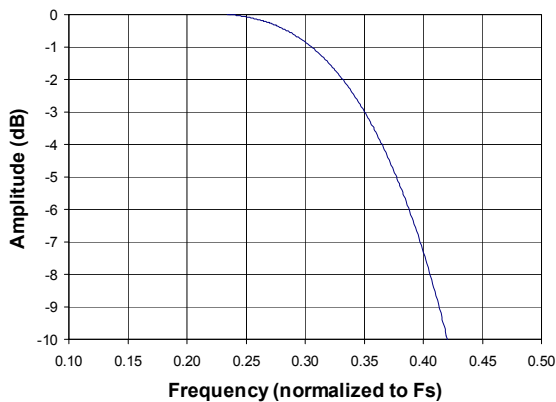
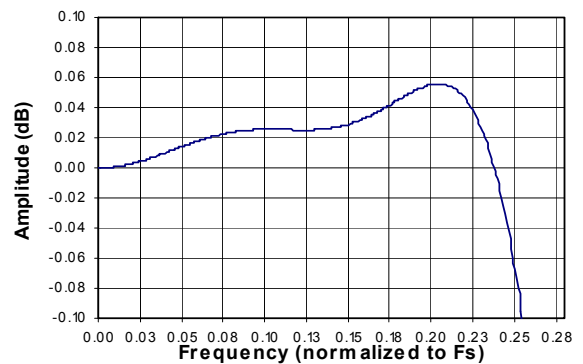

Figure 37. DSM Transition Band

Figure 38. DSM Transition Band (Detail)

Figure 39. DSM Passband Ripple

Figure 40. QSM Stopband Rejection

Figure 41. QSM Transition Band

Figure 42. QSM Transition Band (Detail)

Figure 43. QSM Passband Ripple

9. DAC FILTER PLOTS

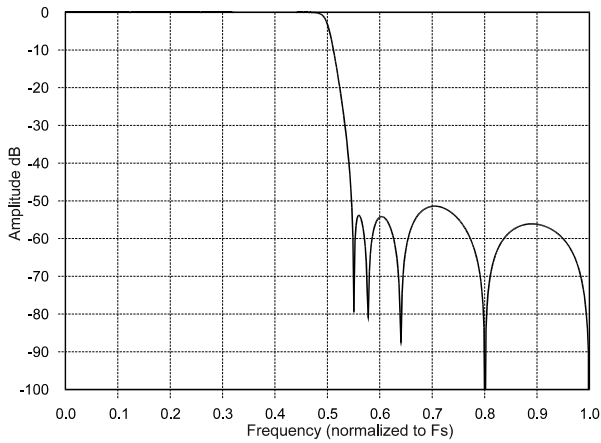

Figure 44. SSM Stopband Rejection

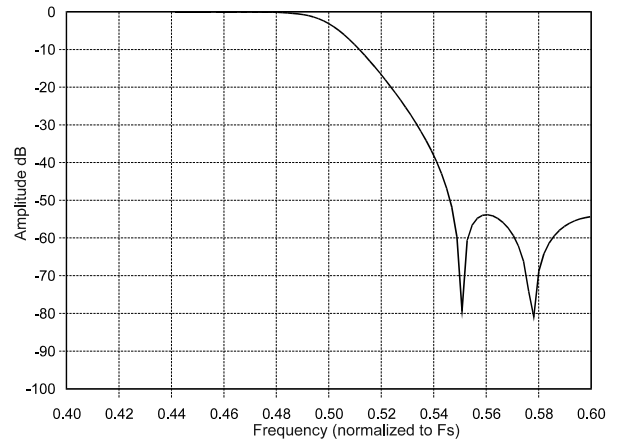

Figure 45. SSM Transition Band

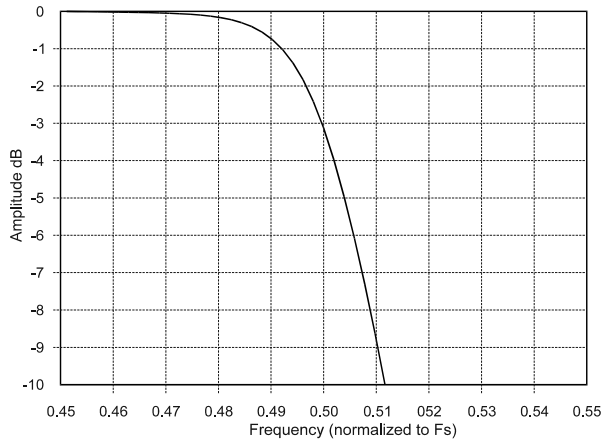

Figure 46. SSM Transition Band (detail)

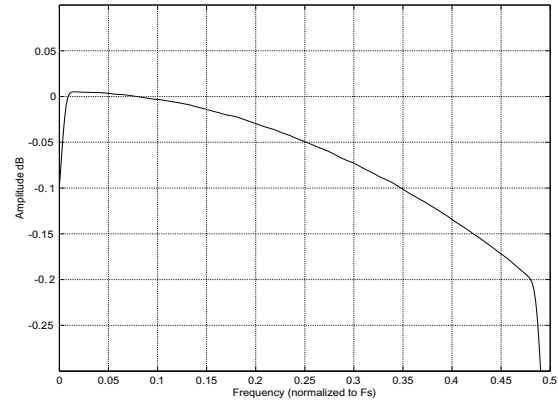

Figure 47. SSM Passband Ripple

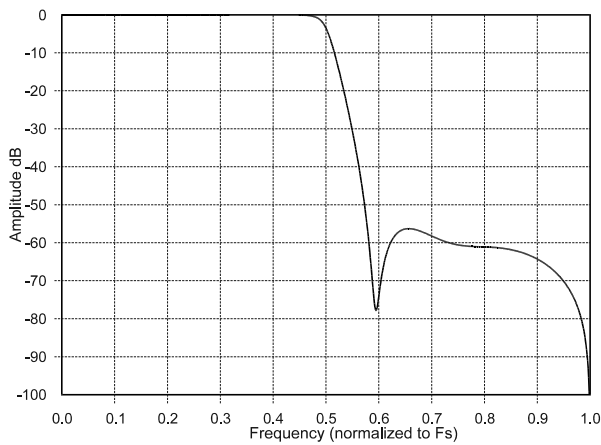

Figure 48. DSM Stopband Rejection

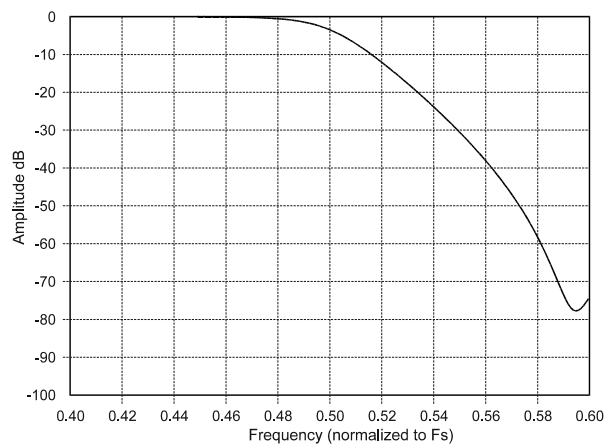
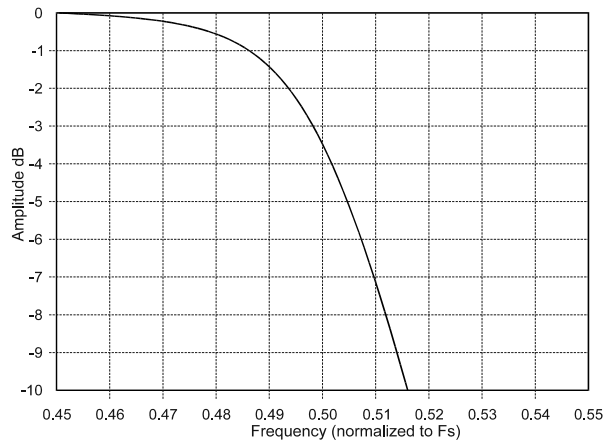
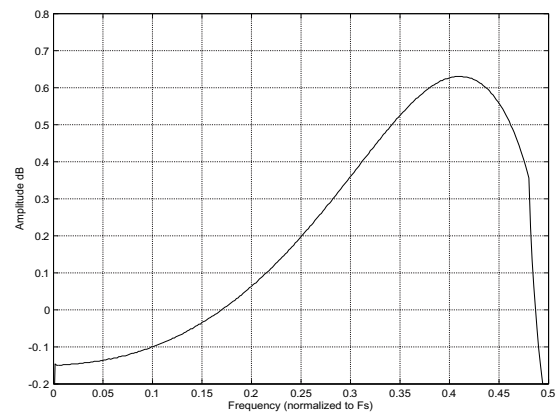
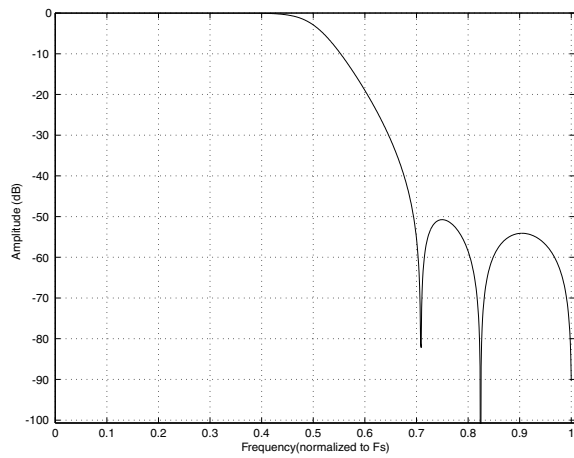
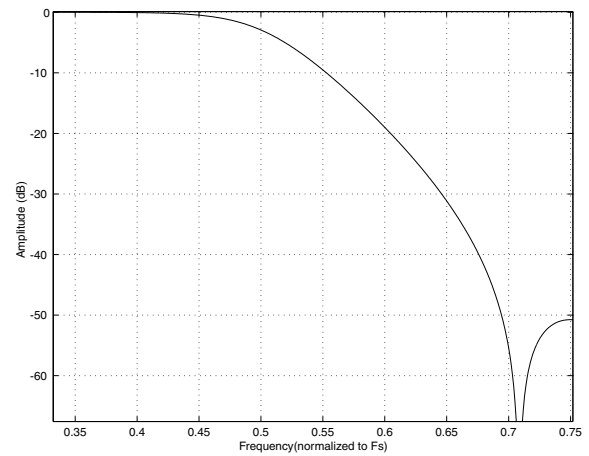
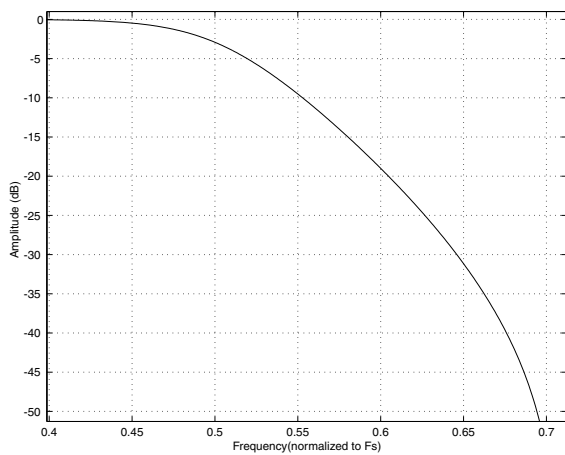
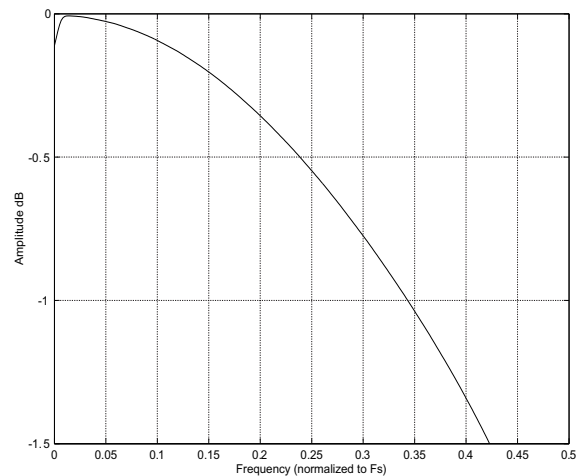

Figure 49. DSM Transition Band

Figure 50. DSM Transition Band (detail)

Figure 51. DSM Passband Ripple

Figure 52. QSM Stopband Rejection

Figure 53. QSM Transition Band

Figure 54. QSM Transition Band (detail)

Figure 55. QSM Passband Ripple

10. PARAMETER DEFINITIONS

Dynamic Range

The ratio of the rms value of the signal to the rms sum of all other spectral components over the specified bandwidth. Dynamic Range is a signal-to-noise ratio measurement over the specified band width made with a -60 dBFS signal. 60 dB is added to resulting measurement to refer the measurement to full-scale. This technique ensures that the distortion components are below the noise level and do not affect the measurement. This measurement technique has been accepted by the Audio Engineering Society, AES17-1991, and the Electronic Industries Association of Japan, EIAJ CP-307. Expressed in decibels.

Total Harmonic Distortion + Noise

The ratio of the rms value of the signal to the rms sum of all other spectral components over the specified band width (typically 10 Hz to 20 kHz), including distortion components. Expressed in decibels. Measured at -1 and -20 dBFS as suggested in AES17-1991 Annex A.

Frequency Response

A measure of the amplitude response variation from 10 Hz to 20 kHz relative to the amplitude response at 1 kHz. Units in decibels.

Interchannel Isolation

A measure of crosstalk between the left and right channel pairs. Measured for each channel at the converter's output with no signal to the input under test and a full-scale signal applied to the other channel. Units in decibels.

Interchannel Gain Mismatch

The gain difference between left and right channel pairs. Units in decibels.

Gain Error

The deviation from the nominal full-scale analog output for a full-scale digital input.

Gain Drift

The change in gain value with temperature. Units in ppm/°C.

Offset Error

The deviation of the mid-scale transition (111...111 to 000...000) from the ideal. Units in mV.

11. REFERENCES

1. Cirrus Logic, *AN18: Layout and Design Rules for Data Converters and Other Mixed Signal Devices*, Version 6.0, February 1998.
2. Cirrus Logic, *Techniques to Measure and Maximize the Performance of a 120 dB, 96 kHz A/D Converter Integrated Circuit*, by Steven Harris, Steven Green and Ka Leung. Presented at the 103rd Convention of the Audio Engineering Society, September 1997.
3. Cirrus Logic, *A Stereo 16-bit Delta-Sigma A/D Converter for Digital Audio*, by D.R. Welland, B.P. Del Signore, E.J. Swanson, T. Tanaka, K. Hamashita, S. Hara, K. Takasuka. Paper presented at the 85th Convention of the Audio Engineering Society, November 1988.
4. Cirrus Logic, *The Effects of Sampling Clock Jitter on Nyquist Sampling Analog-to-Digital Converters, and on Oversampling Delta Sigma ADC's*, by Steven Harris. Paper presented at the 87th Convention of the Audio Engineering Society, October 1989.
5. Cirrus Logic, *An 18-Bit Dual-Channel Oversampling Delta-Sigma A/D Converter, with 19-Bit Mono Application Example*, by Clif Sanchez. Paper presented at the 87th Convention of the Audio Engineering Society, October 1989.
6. Cirrus Logic, *How to Achieve Optimum Performance from Delta-Sigma A/D and D/A Converters*, by Steven Harris. Presented at the 93rd Convention of the Audio Engineering Society, October 1992.
7. Cirrus Logic, *A Fifth-Order Delta-Sigma Modulator with 110 dB Audio Dynamic Range*, by I. Fujimori, K. Hamashita and E.J. Swanson. Paper presented at the 93rd Convention of the Audio Engineering Society, October 1992.
8. Philips Semiconductor, *The I²C-Bus Specification: Version 2.1*, January 2000.
<http://www.semiconductors.philips.com>

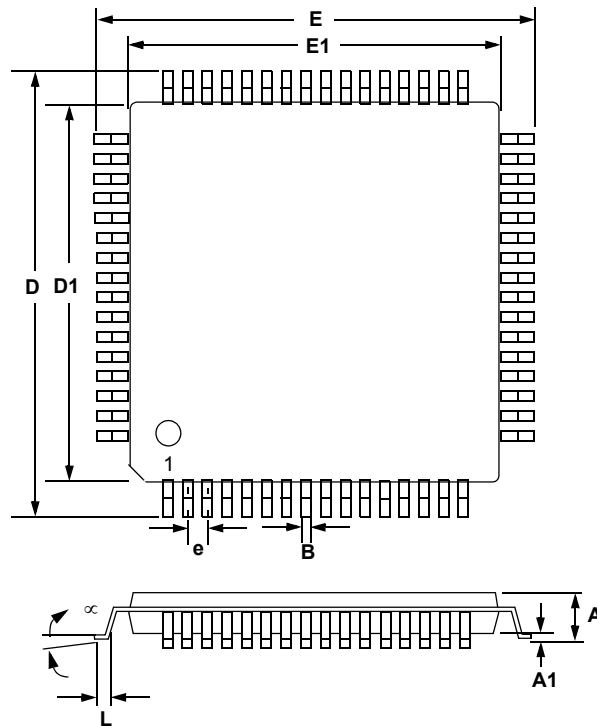
12.PACKAGE INFORMATION
64L LQFP PACKAGE DRAWING

DIM	INCHES			MILLIMETERS		
	MIN	NOM	MAX	MIN	NOM	MAX
A	---	0.55	0.063	---	1.40	1.60
A1	0.002	0.004	0.006	0.05	0.10	0.15
B	0.007	0.008	0.011	0.17	0.20	0.27
D	0.461	0.472 BSC	0.484	11.70	12.0 BSC	12.30
D1	0.390	0.393 BSC	0.398	9.90	10.0 BSC	10.10
E	0.461	0.472 BSC	0.484	11.70	12.0 BSC	12.30
E1	0.390	0.393 BSC	0.398	9.90	10.0 BSC	10.10
e*	0.016	0.020 BSC	0.024	0.40	0.50 BSC	0.60
L	0.018	0.024	0.030	0.45	0.60	0.75
∞	0.000°	4°	7.000°	0.00°	4°	7.00°

* Nominal pin pitch is 0.50 mm
 Controlling dimension is mm.
 JEDEC Designation: MS026

12.1 Thermal Characteristics

Parameter		Symbol	Min	Typ	Max	Units
Junction to Ambient Thermal Impedance	2 Layer Board	θ_{JA}	-	50	-	°C/Watt
	4 Layer Board	θ_{JA}	-	37	-	°C/Watt

13. ORDERING INFORMATION

Product	Description	Package	Pb-Free	Grade	Temp Range	Container	Order #
CS42448	6-in, 8-out CODEC for Surround Sound Apps	64L-LQFP	YES	Commercial	-10° to +70° C	Rail	CS42448-CQZ
						Tape & Reel	CS42448-CQZR
				Automotive	-40° to +105° C	Rail	CS42448-DQZ
						Tape & Reel	CS42448-DQZR
CDB42448	CS42448 evaluation board	-	-	-	-	-	CDB42448

14. REVISION HISTORY

Revision	Changes
F1	Updated temperature and voltage specifications in the “Recommended Operating Conditions” on page 10. Added test conditions to the Analog Input and Analog Output Characteristics tables.
F2	Corrected polarities for pin numbers 31, 32, 38, 39 in the “Typical Connection Diagram” on page 9 and corrected the number designations for the AOUT7+ and AOUT7- pins in the Pin Descriptions table on page 6.
F3	Updated input impedance specification for Differential and Single-Ended Inputs in “Analog Input Characteristics (Commercial)” on page 11 and “Analog Input Characteristics (Automotive)” on page 12.
F4	<ul style="list-style-type: none"> Updated Note 12 regarding triangular PDF dither in “Analog Output Characteristics (Automotive)” on page 15. Added rows for “High-Level Output Voltage at $I_o=100\ \mu\text{A}$” and “Low-Level Output Voltage at $I_o=100\ \mu\text{A}$” in “Digital Interface Specifications & Characteristics” on page 24. Updated MFreq2:0 == 001 and MFreq2:0 == 011 (ratios of 384x and 768x) to “Reserved” in Table 10 and Table 11. Removed references to these ratios and their divisors in Table 2 through Table 8.
F5	Updates to clarify the behavior of the ADC Overflow bit; full-scale signal with single-ended input. <ul style="list-style-type: none"> Explanatory text preceding Figure 10 on page 26. Explanatory text, “ADC Overflow (ADCX_OVFL)” on page 52.

Contacting Cirrus Logic Support

For all product questions and inquiries, contact a Cirrus Logic Sales Representative.
To find the one nearest you, go to www.cirrus.com.

IMPORTANT NOTICE

The products and services of Cirrus Logic International (UK) Limited; Cirrus Logic, Inc.; and other companies in the Cirrus Logic group (collectively either "Cirrus Logic" or "Cirrus") are sold subject to Cirrus Logic's terms and conditions of sale supplied at the time of order acknowledgment, including those pertaining to warranty, indemnification, and limitation of liability. Software is provided pursuant to applicable license terms. Cirrus Logic reserves the right to make changes to its products and specifications or to discontinue any product or service without notice. Customers should therefore obtain the latest version of relevant information from Cirrus Logic to verify that the information is current and complete. Testing and other quality control techniques are utilized to the extent Cirrus Logic deems necessary. Specific testing of all parameters of each device is not necessarily performed. In order to minimize risks associated with customer applications, the customer must use adequate design and operating safeguards to minimize inherent or procedural hazards. Cirrus Logic is not liable for applications assistance or customer product design. The customer is solely responsible for its selection and use of Cirrus Logic products. Use of Cirrus Logic products may entail a choice between many different modes of operation, some or all of which may require action by the user, and some or all of which may be optional. Nothing in these materials should be interpreted as instructions or suggestions to choose one mode over another. Likewise, description of a single mode should not be interpreted as a suggestion that other modes should not be used or that they would not be suitable for operation. Features and operations described herein are for illustrative purposes only.

CERTAIN APPLICATIONS USING SEMICONDUCTOR PRODUCTS MAY INVOLVE POTENTIAL RISKS OF DEATH, PERSONAL INJURY, OR SEVERE PROPERTY OR ENVIRONMENTAL DAMAGE ("CRITICAL APPLICATIONS"). CIRRUS LOGIC PRODUCTS ARE NOT DESIGNED, AUTHORIZED OR WARRANTED FOR USE IN PRODUCTS SURGICALLY IMPLANTED INTO THE BODY, AUTOMOTIVE SAFETY OR SECURITY DEVICES, NUCLEAR SYSTEMS, LIFE SUPPORT PRODUCTS OR OTHER CRITICAL APPLICATIONS. INCLUSION OF CIRRUS LOGIC PRODUCTS IN SUCH APPLICATIONS IS UNDERSTOOD TO BE FULLY AT THE CUSTOMER'S RISK AND CIRRUS LOGIC DISCLAIMS AND MAKES NO WARRANTY, EXPRESS, STATUTORY OR IMPLIED, INCLUDING THE IMPLIED WARRANTIES OF MERCHANTABILITY AND FITNESS FOR PARTICULAR PURPOSE, WITH REGARD TO ANY CIRRUS LOGIC PRODUCT THAT IS USED IN SUCH A MANNER. IF THE CUSTOMER OR CUSTOMER'S CUSTOMER USES OR PERMITS THE USE OF CIRRUS LOGIC PRODUCTS IN CRITICAL APPLICATIONS, CUSTOMER AGREES, BY SUCH USE, TO FULLY INDEMNIFY CIRRUS LOGIC, ITS OFFICERS, DIRECTORS, EMPLOYEES, DISTRIBUTORS AND OTHER AGENTS FROM ANY AND ALL LIABILITY, INCLUDING ATTORNEYS' FEES AND COSTS, THAT MAY RESULT FROM OR ARISE IN CONNECTION WITH THESE USES.

This document is the property of Cirrus Logic and by furnishing this information, Cirrus Logic grants no license, express or implied, under any patents, mask work rights, copyrights, trademarks, trade secrets or other intellectual property rights. Any provision or publication of any third party's products or services does not constitute Cirrus Logic's approval, license, warranty or endorsement thereof. Cirrus Logic gives consent for copies to be made of the information contained herein only for use within your organization with respect to Cirrus Logic integrated circuits or other products of Cirrus Logic, and only if the reproduction is without alteration and is accompanied by all associated copyright, proprietary and other notices and conditions (including this notice). This consent does not extend to other copying such as copying for general distribution, advertising or promotional purposes, or for creating any work for resale. This document and its information is provided "AS IS" without warranty of any kind (express or implied). All statutory warranties and conditions are excluded to the fullest extent possible. No responsibility is assumed by Cirrus Logic for the use of information herein, including use of this information as the basis for manufacture or sale of any items, or for infringement of patents or other rights of third parties. Cirrus Logic, Cirrus, the Cirrus Logic logo design, and SoundClear are among the trademarks of Cirrus Logic. Other brand and product names may be trademarks or service marks of their respective owners.

Copyright © 2013–2017 Cirrus Logic, Inc. All rights reserved.

SPI is a trademark of Motorola.

Mouser Electronics

Authorized Distributor

Click to View Pricing, Inventory, Delivery & Lifecycle Information:

[Cirrus Logic:](#)

[CDB42448](#) [CS42448-CQZ](#) [CS42448-CQZR](#) [CS42448-DQZ](#) [CS42448-DQZR](#)