

# Housing - HC-B 32-SMQ-72/M1PG29 - 1775703

Please be informed that the data shown in this PDF Document is generated from our Online Catalog. Please find the complete data in the user's documentation. Our General Terms of Use for Downloads are valid (<http://phoenixcontact.com/download>)



Box mounting base, with double locking latch, height 72 mm, with screw connection, 1x Pg29



## Key Commercial Data

Packing unit	10 pc
GTIN	
GTIN	4017918038274

## Technical data

### Dimensions

Height	72 mm
Width	81.5 mm
Length	124 mm
Wrench size, union nut	37 mm
External cable diameter	18 mm ... 27 mm

### Ambient conditions

Degree of protection (IP)	IP65
Ambient temperature (operation)	-40 °C ... 125 °C

### General

Note	For contact inserts HC-B32, DD144, M
Size	B32
Housing type	Box mounting bases
Color	gray aluminum
Locking type	with double locking latch
No. of cable outlets	1
Cable outlet	lateral
Screw connection	with

# Housing - HC-B 32-SMQ-72/M1PG29 - 1775703

## Technical data

### General

Type of the screw connection	1x Pg29
Housing material	Aluminum die-cast
Housing surface material	Powder-coated, gray
Seal material	NBR
Cable gland material	Nickel-plated brass
Cable seal material	NBR
Material lock	Steel, galvanized

### Environmental Product Compliance

China RoHS	Environmentally friendly use period: unlimited = EFUP-e
	No hazardous substances above threshold values

## Drawings

Dimensional drawing

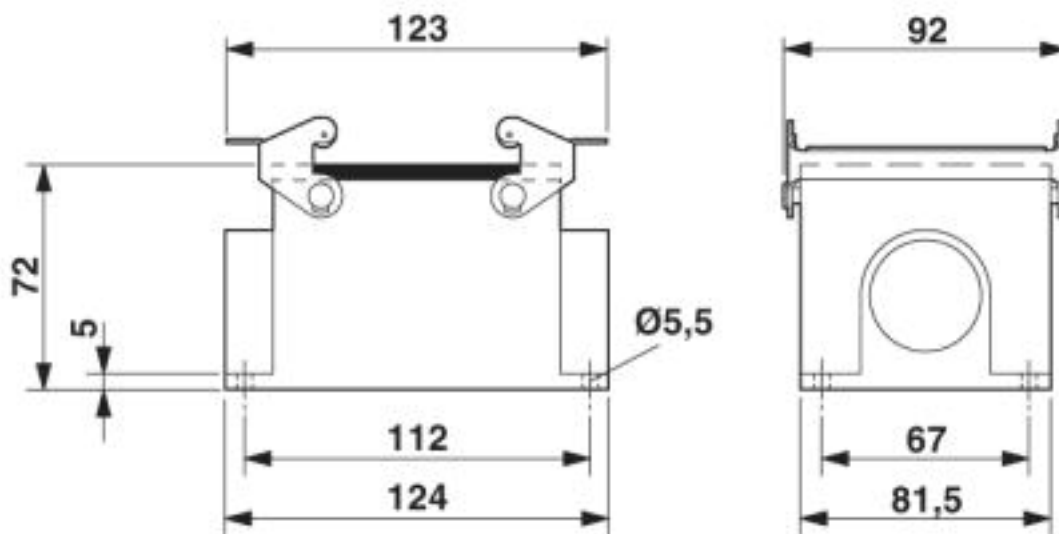

Dimensional drawing

## Classifications

eCl@ss

eCl@ss 10.0.1	27440202
eCl@ss 4.0	27140800
eCl@ss 4.1	27140800
eCl@ss 5.0	27143400
eCl@ss 5.1	27261200
eCl@ss 6.0	27261200
eCl@ss 7.0	27440202

# Housing - HC-B 32-SMQ-72/M1PG29 - 1775703

## Classifications

### eCl@ss

eCl@ss 8.0	27440202
eCl@ss 9.0	27440202

### ETIM

ETIM 2.0	EC000437
ETIM 3.0	EC000437
ETIM 4.0	EC000437
ETIM 5.0	EC000437
ETIM 6.0	EC000437
ETIM 7.0	EC000437

### UNSPSC

UNSPSC 6.01	31261502
UNSPSC 7.0901	31261502
UNSPSC 11	31261502
UNSPSC 12.01	31261502
UNSPSC 13.2	31261501
UNSPSC 18.0	31261501
UNSPSC 19.0	31261501
UNSPSC 20.0	31261501
UNSPSC 21.0	31261501

## Approvals

### Approvals

---

Approvals

EAC

---

Ex Approvals

---

### Approval details

EAC		RU C- DE.AI30.B.01102
-----	---	--------------------------

---

Phoenix Contact 2020 © - all rights reserved  
<http://www.phoenixcontact.com>

PHOENIX CONTACT GmbH & Co. KG  
Flachmarktstr. 8  
32825 Blomberg  
Germany  
Tel. +49 5235 300  
Fax +49 5235 3 41200  
<http://www.phoenixcontact.com>