

**\*\*NOTE: CONTACTS MUST BE PURCHASED SEPARATELY\*\***

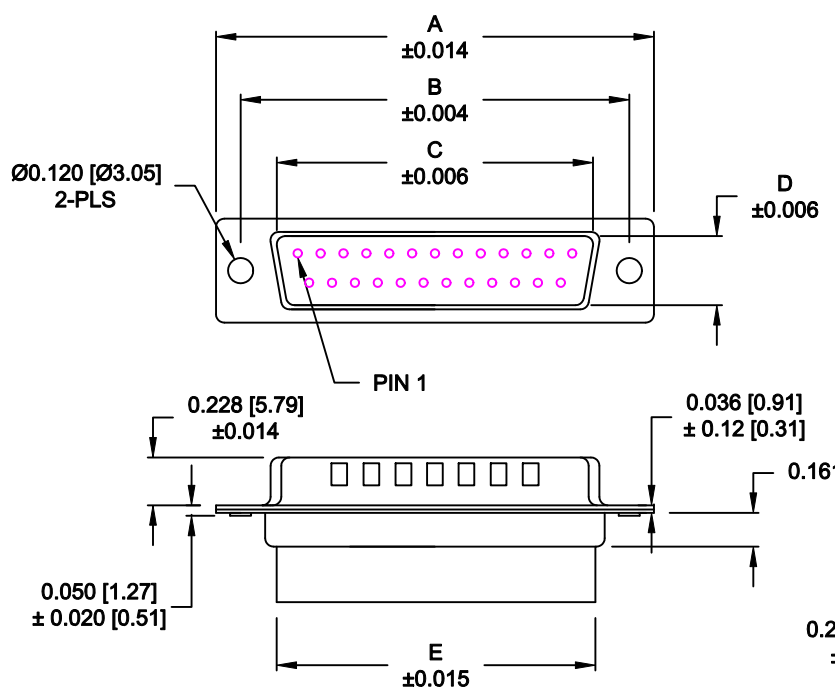

No. OF PINS	DIMENSIONS						
	A	B	C	D	E	F	G
9	1.213	0.984	0.669	0.331	0.618	0.496	0.429
	30.80	24.99	17.00	8.40	15.70	12.60	10.90
15	1.541	1.312	0.996	0.331	0.933	0.496	0.429
	39.15	33.32	25.30	8.40	23.70	12.60	10.90
25	2.088	1.852	1.535	0.331	1.496	0.496	0.429
	53.04	47.04	39.00	8.40	38.00	12.60	10.90
37	2.729	2.500	2.181	0.331	2.142	0.496	0.429
	69.32	63.50	55.40	8.40	54.40	12.60	10.90
50	2.635	2.406	2.079	0.437	2.039	0.602	0.535
	66.93	61.11	52.80	11.10	51.80	15.30	13.60

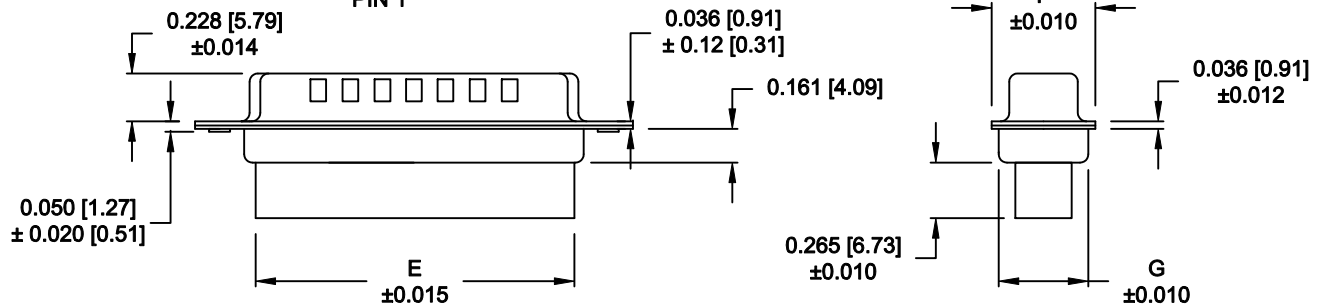

**170-YYY-17YL000**

- SERIES \_\_\_\_\_
- POSITIONS \_\_\_\_\_
- 009 \_\_\_\_\_
- 015 \_\_\_\_\_
- 025 \_\_\_\_\_
- 037 \_\_\_\_\_
- 050 \_\_\_\_\_
- GENDER \_\_\_\_\_
- 1 = MALE \_\_\_\_\_
- TERMINATION \_\_\_\_\_
- 7 = CRIMP & LOAD \_\_\_\_\_
- SHELL PLATING \_\_\_\_\_
- 2 = TIN (GROUND INDENTS) \_\_\_\_\_
- 3 = NICKEL (GROUND INDENTS) \_\_\_\_\_
- RoHS COMPLIANT \_\_\_\_\_
- HARDWARE OPTIONS \_\_\_\_\_
- 00 = NO HARDWARE \_\_\_\_\_
- 01 = .098" CLINCH NUT (BOARD SIDE) \_\_\_\_\_
- 02 = .236" CLINCH NUT (BOARD SIDE) \_\_\_\_\_
- 03 = .236" CLINCH NUT (MATING SIDE) \_\_\_\_\_
- PLATING OPTIONS \_\_\_\_\_
- 0 = NO CONTACTS \_\_\_\_\_

**MATERIAL:**

SHELL: STEEL, TIN OR NICKEL PLATED  
 INSULATOR: UL 94V-O RATED, PBT +30% FIBER-GLASS

**ELECTRICAL:**

CURRENT RATING: 5 AMPS  
 CONTACT RESISTANCE: 15 mOhms Max.  
 INSULATION RESISTANCE: 1,000 MOhms min.  
 VOLTAGE: 500VAC FOR 1 MINUTE  
 TEMPERATURE: -50° C TO 125° C

**DO NOT SCALE FROM DRAWING**

**RoHS COMPLIANT**

	THESE DRAWINGS AND SPECIFICATIONS ARE THE PROPERTY OF NorComp AND SHALL NOT BE REPRODUCED, COPIED OR USED AS THE BASIS FOR THE MANUFACTURE OF SALE OF APPARATUS WITHOUT WRITTEN PERMISSION.		DRAWN: <b>PAM JENKINS</b>	DATE: <b>8-18-98</b>
			CHECKED:	DATE:
<b>NorComp</b>		SCALE: <b>1 : 1</b>	SHEET <b>1</b> OF <b>2</b>	REV <b>11</b>
		DWG NO. <b>170-YYY-17YL000</b>		

**TOLERANCE:**  
ALL DIMENSIONS ARE ±0.010

**ALL CLINCH-NUTS ARE 4-40 INTERNAL THREADS**

01X ..... 0.065" (BOARD SIDE) - CN1

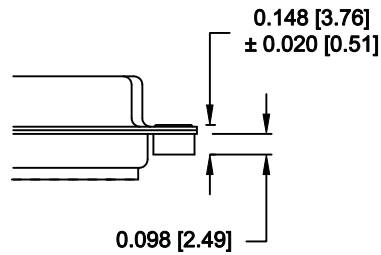

02X ..... 0.236" (BOARD SIDE) - CN2

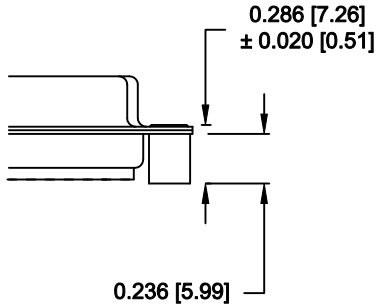

03X..... 0.236" (MATING SIDE) - CN8

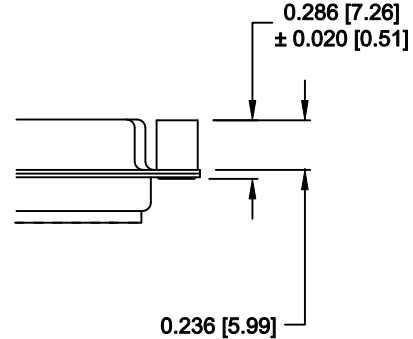

**DO NOT SCALE FROM DRAWING**

	THESE DRAWINGS AND SPECIFICATIONS ARE THE PROPERTY OF NorComp AND SHALL NOT BE REPRODUCED, COPIED OR USED AS THE BASIS FOR THE MANUFACTURE OF SALE OF APPARATUS WITHOUT WRITTEN PERMISSION.		DRAWN: <b>C. SMITH</b>	DATE: <b>03-08-06</b>
			CHECKED:	DATE:
NorComp		SCALE: <b>FULL</b>	SHEET <b>2</b> OF <b>2</b>	REV <b>11</b>
		DWG NO. <b>170-YYY-17YL000</b>		

**RoHS COMPLIANT**

# Mouser Electronics

Authorized Distributor

Click to View Pricing, Inventory, Delivery & Lifecycle Information:

## NorComp:

[170-015-171L000](#) [170-009-173L000](#) [170-050-173L000](#) [170-009-171L000](#) [170-009-173L010](#) [170-009-173L020](#)  
[170-009-173L030](#) [170-015-173L010](#) [170-015-173L020](#) [170-015-173L030](#) [170-025-173L020](#) [170-025-173L030](#) [170-](#)  
[037-173L010](#) [170-037-173L020](#) [170-037-173L030](#) [170-050-173L010](#) [170-050-173L020](#) [170-050-173L030](#) [170-025-](#)  
[171L000](#) [170-050-171L000](#) [170-015-173L000](#) [170-037-171L000](#) [170-025-173L000](#) [170-037-273L000](#) [170-037-](#)  
[173L000](#) [170-025-173L010](#) [170-009-172L000](#) [170-015-172L000](#) [170-025-172L000](#) [170-037-172L000](#) [170-050-](#)  
[172L000](#) [170-050-172L010](#) [170-050-172L020](#) [170-050-172L030](#) [170-009-172-000](#) [170-050-171-000](#) [170-025-172-](#)  
[000](#) [170-037-172-000](#) [170-037-171-000](#) [170-015-171-000](#) [170-009-171-000](#) [170-050-172-000](#) [170-025-171-000](#)  
[170-015-172-000](#)